

LT
(LT...CE, LT...LD, LT...H)

LT

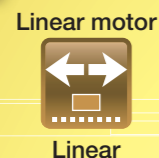

Compact, high thrust, and long stroke LT series!

Linear Motor Table LT is a compact and high-precision positioning table with an optical linear encoder built in and with AC linear servomotor incorporated between moving table and bed. Lightweight moving table and large thrust force enables the operation of high acceleration / deceleration and high response. And, the advanced servo technology achieves high static stability and speed stability.

Three types, consisting of Compact type LT...CE, Long stroke type LT...LD, and High thrust type LT...H, are listed on lineup, which allows customers to select the most suitable model depending on the usage.

Linear Motor Table LT specification list

Model and size	Compact type LT...CE								
	LT100CEG			LT150CEG			LT150CETF		
Thrust / speed specification	High thrust specification			High thrust specification 1			High thrust specification 2		
Sectional shape									
Maximum thrust N	120			350			390		
Rated thrust N	15			60			70		
Maximum load mass kg	12			35			39		
Effective stroke length mm	1000			1200			1200		
Resolution μm	0.1	0.5	1.0	0.1	0.5	1.0	0.1	0.5	1.0
Maximum speed mm/s	700	2000	2000	700	2000	2000	700	2000	2000
Positioning repeatability μm	±0.5	±0.5	±1.0	±0.5	±0.5	±1.0	±0.5	±0.5	±1.0

Model and size	Long stroke type LT...LD												High thrust type LT...H		
	LT130LDG			LT170LDG			LT170LDV			LT170LDTF			LT170H		
Thrust / speed specification	High thrust specification			High thrust specification 1			High speed specification			High thrust specification 2			—		
Sectional shape															
Maximum thrust N	120			350			145			390			900		
Rated thrust N	15			60			25			70			Natural air cooling : 120 Air cooling : 150		
Maximum load mass kg	12			35			20			39			90		
Effective stroke length mm	2760			2720			2720			1640			2670		
Resolution μm	0.1	0.5	1.0	0.1	0.5	1.0	0.1	0.5	1.0	0.1	0.5	1.0	0.1	0.5	1.0
Maximum speed mm/s	700	2000	3000	700	2000	2000	700	2000	3000	700	2000	2000	700	1500 (2000)	1500 (2000)
Positioning repeatability μm	±0.5	±0.5	±1.0	±0.5	±0.5	±1.0	±0.5	±0.5	±1.0	±0.5	±0.5	±1.0	±0.5	±0.5	±1.0

Major product specifications

Driving method	Linear motor
Linear motion rolling guide	Linear Way (ball type)
Built-in lubrication part	Lubrication part "C-Lube" is built-in
Material of table and bed	High-strength aluminum alloy (High carbon steel is used for the LT100CE bed)
Sensor	Select by identification number

Accuracy

Positioning repeatability	±0.0005~0.0010
Positioning accuracy	—
Lost motion	—
Parallelism in table motion A	—
Parallelism in table motion B	—
Attitude accuracy	—
Straightness	—
Backlash	—

unit: mm

Sectional Structure of Linear Motor Table LT

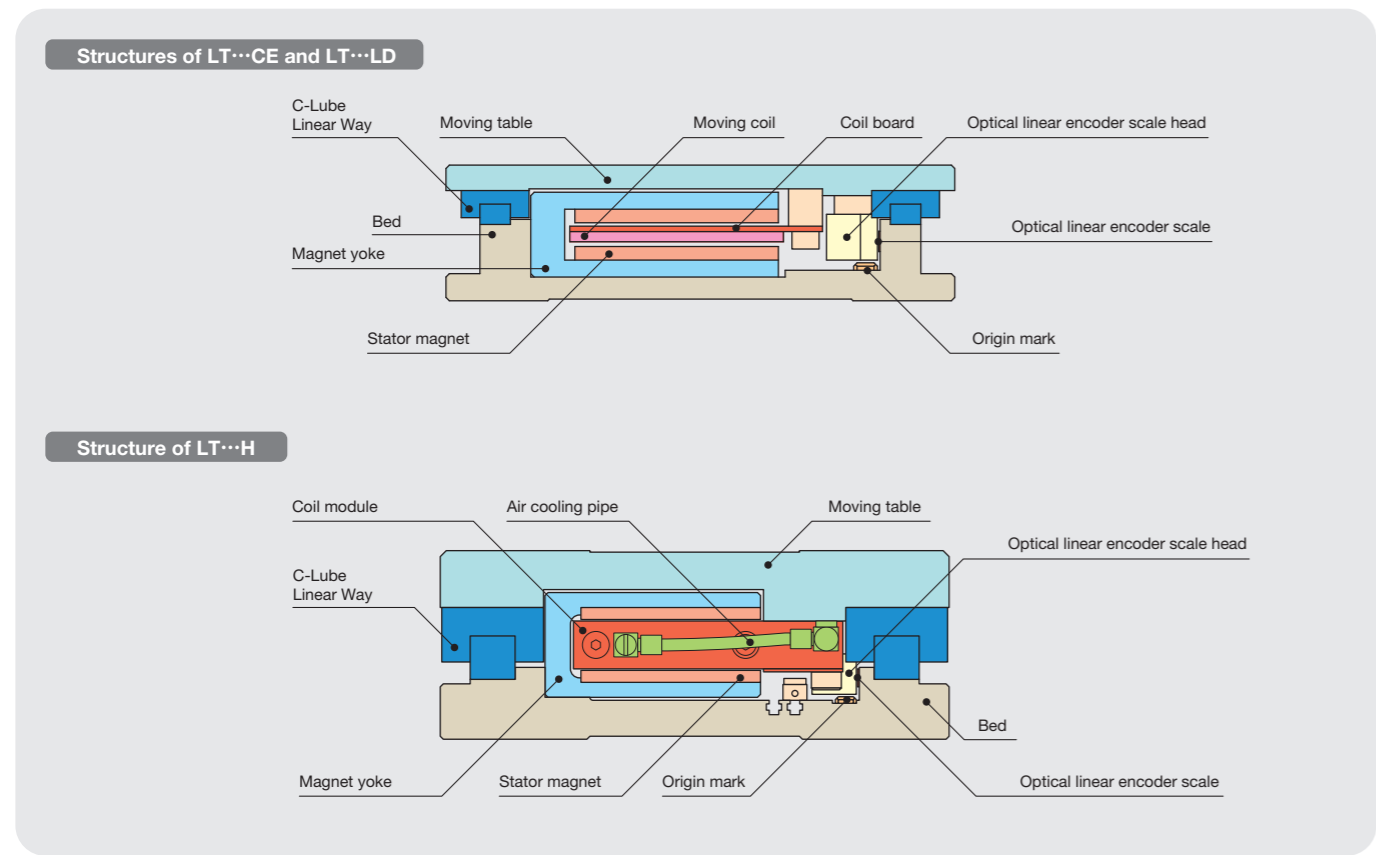

Operating principle of Linear Motor Table LT

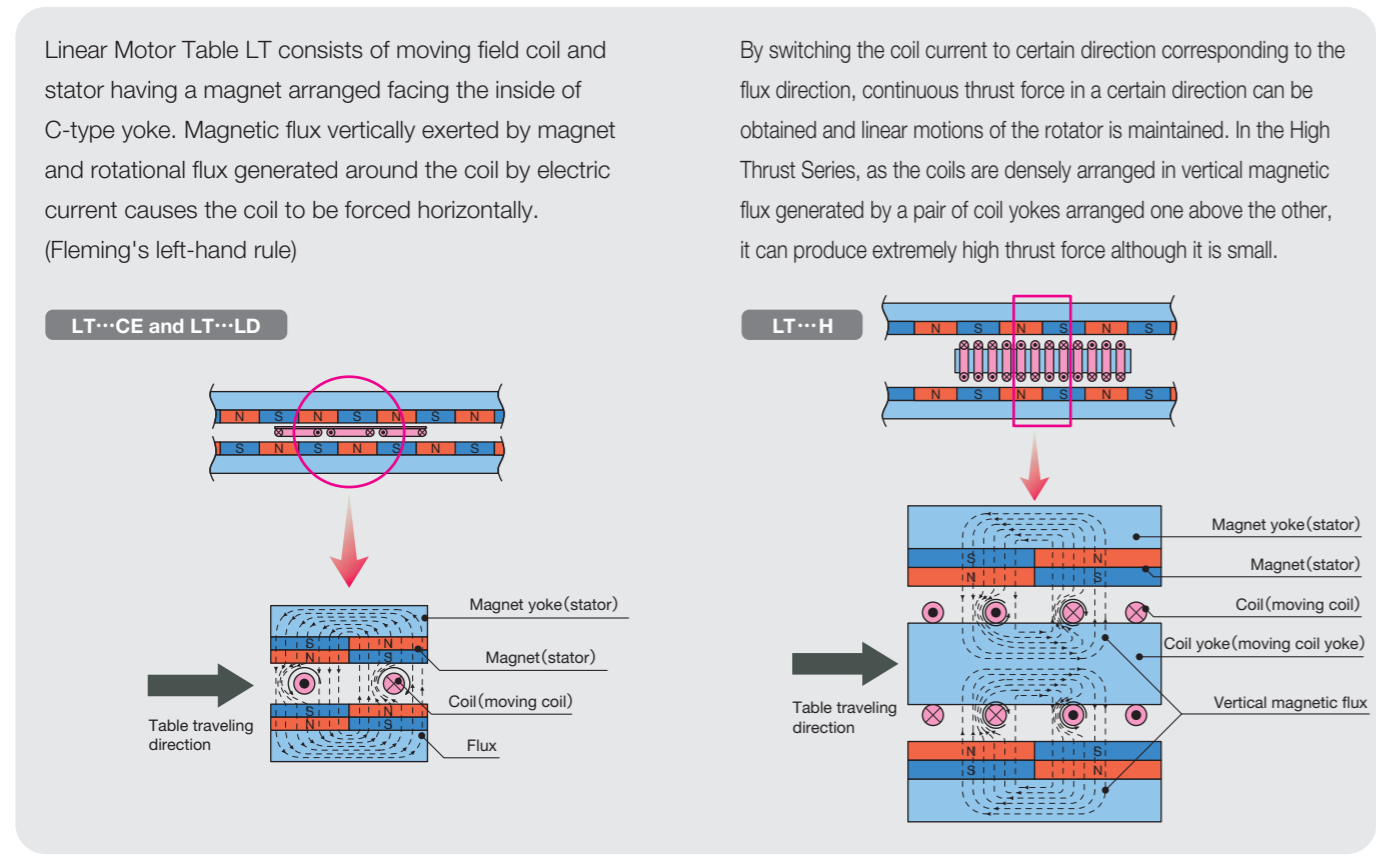

LT...CE [Compact type]

LT...CE is a compact linear motor table with high thrust force generating capability, which uses C-Lube Linear Way ML, miniature linear motion rolling guide in the table guiding parts and adopts lightweight aluminum alloy in the moving table.

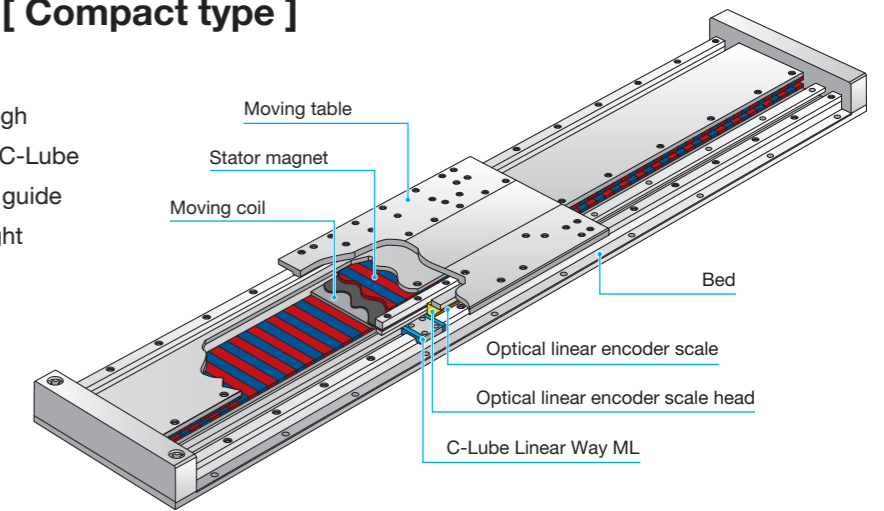

Points

1 ● Compact

Low profile design with downsizing thoroughly pursued by adopting C-Lube Linear Way ML and small optical linear encoder. Minimum sectional height of 30mm (LT100CE) is achieved.

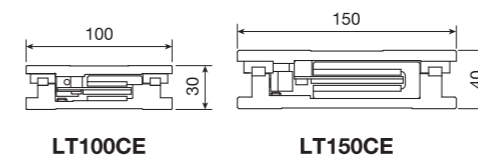

2 ● Static stability

Advanced servo technology has achieved high static stability.

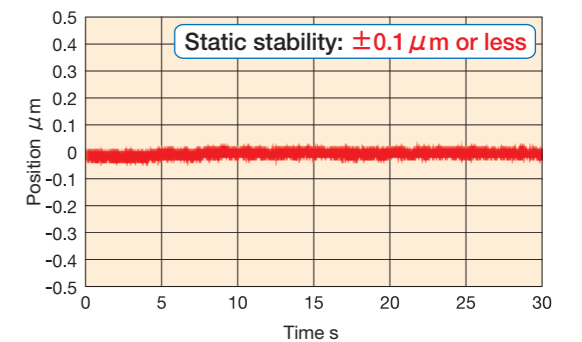

* Value when using ADVA driver.

3 ● High speed stability

Direct drive and advanced servo technology has achieved high speed stability.

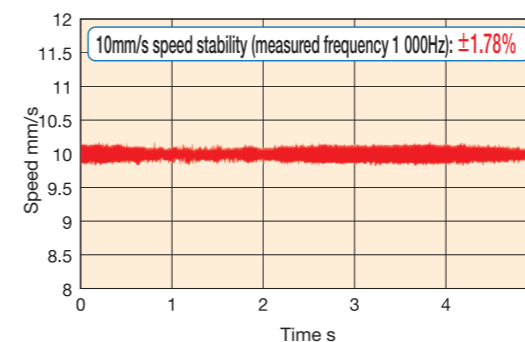

* Value when using ADVA driver.

4 ● High acceleration / deceleration and high response

This unit is small but can produce a great thrust force. Aluminum alloy-made and lightweight moving table has achieved the positioning by high acceleration / deceleration and high response. It contributes to shortening of tact time.

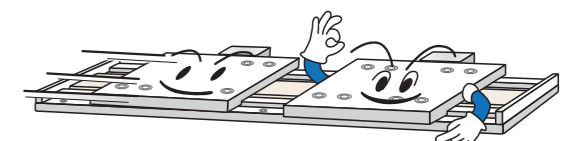

1N=0.102kgf=0.2248lbs.
1mm=0.03937inch

LT...LD

[Long stroke type]

Using C-Lube Linear Way ME of the jointing specification track rail in the table guiding parts, the LT...LD is a linear motor table enabling the long stroke and high-speed operation.

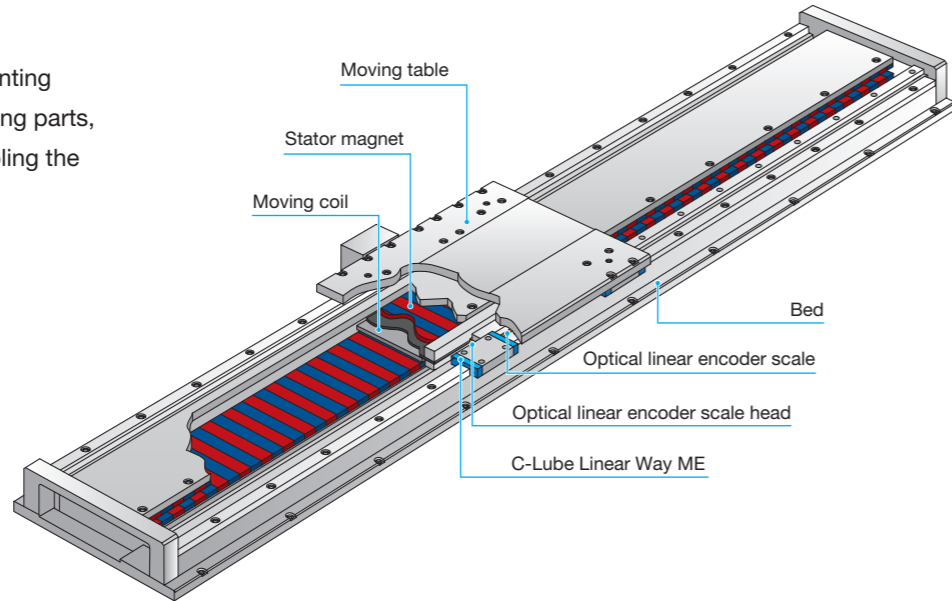

Points

1 High speed

Direct drive enables both high-precision positioning and high speed. Supports high speed operation required for long stroke motion. It is possible to perform high-speed motion of up to 3,000mm/s.

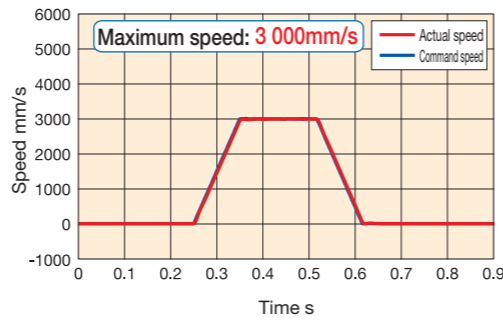
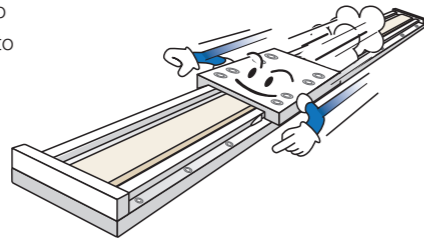

* Value when using ADVA driver.

2 Super long stroke

Adopting C-Lube Linear Way ME of jointing specification track rail, this unit has achieved long stroke of up to 2,760mm specific to linear motor driving. (For stroke products longer than this, please consult IKO.)

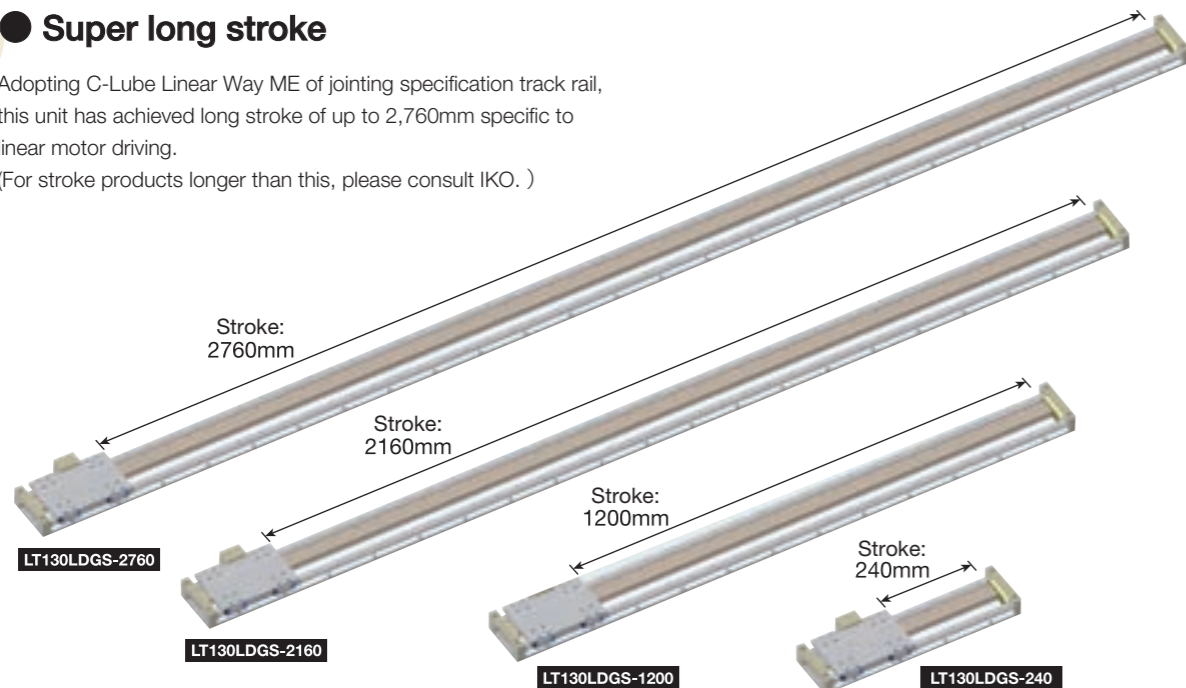

LT...H

[High thrust type]

LT...H uses C-Lube Linear Way ME in the table guiding parts and can produce the biggest thrust force among Linear Motor Table LT units without impairing the compact feature, so that it is a linear motor table best suited for precision positioning of a heavy load.

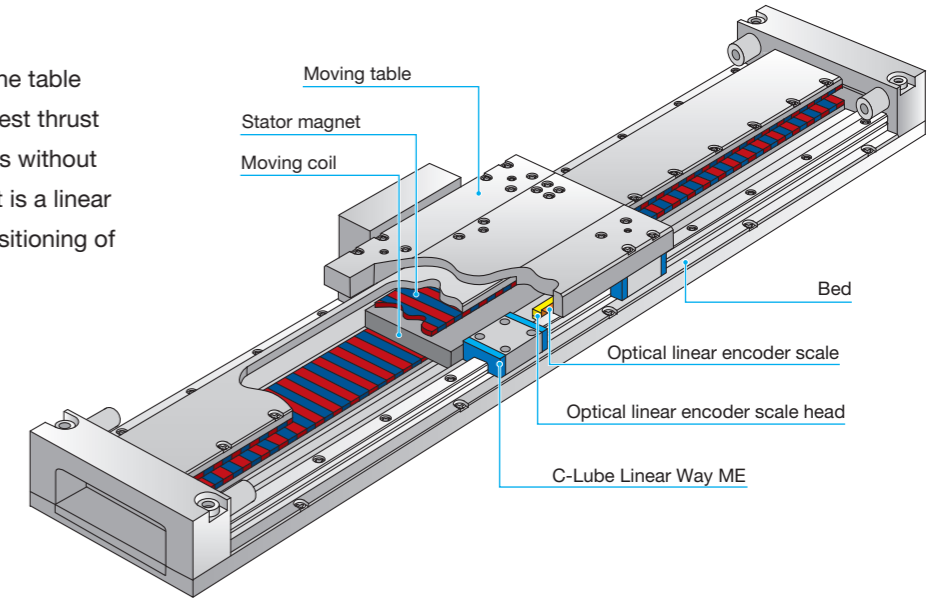

Points

1 High thrust

Although this table is compact in shape, it can produce maximum thrust force of 900N. This unit is best suited to the precision positioning of heavy load.

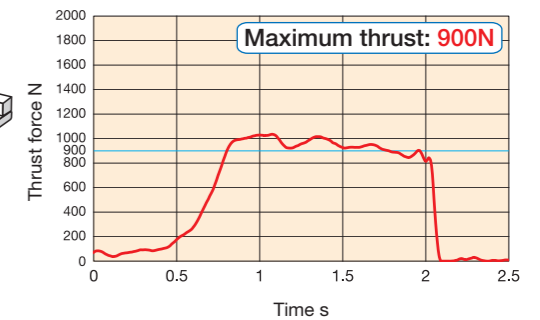
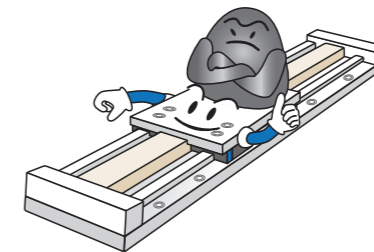

2 High acceleration / deceleration

Lightweight table and high thrust have achieved high acceleration / deceleration and high response.

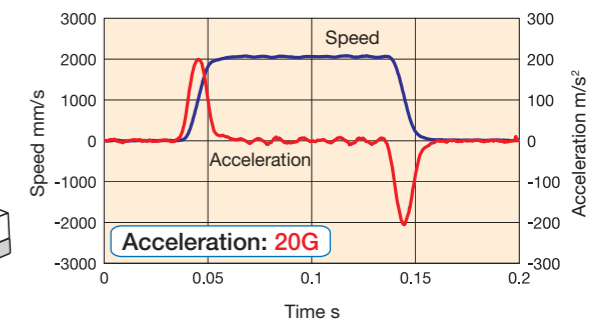
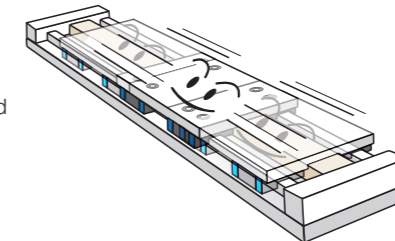

3 Air cooling

Cooling mechanism for suppressing the heating of motor section is optionally set. It enables shortening of tact time and contributes to improving the production efficiency.

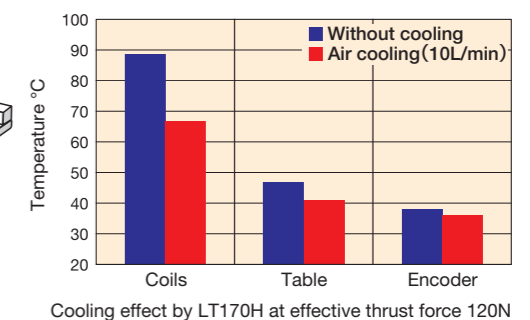
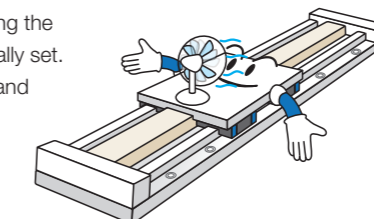

Cooling effect by LT170H at effective thrust force 120N

1N=0.102kgf=0.2248lbs.
1mm=0.03937inch

Identification Number

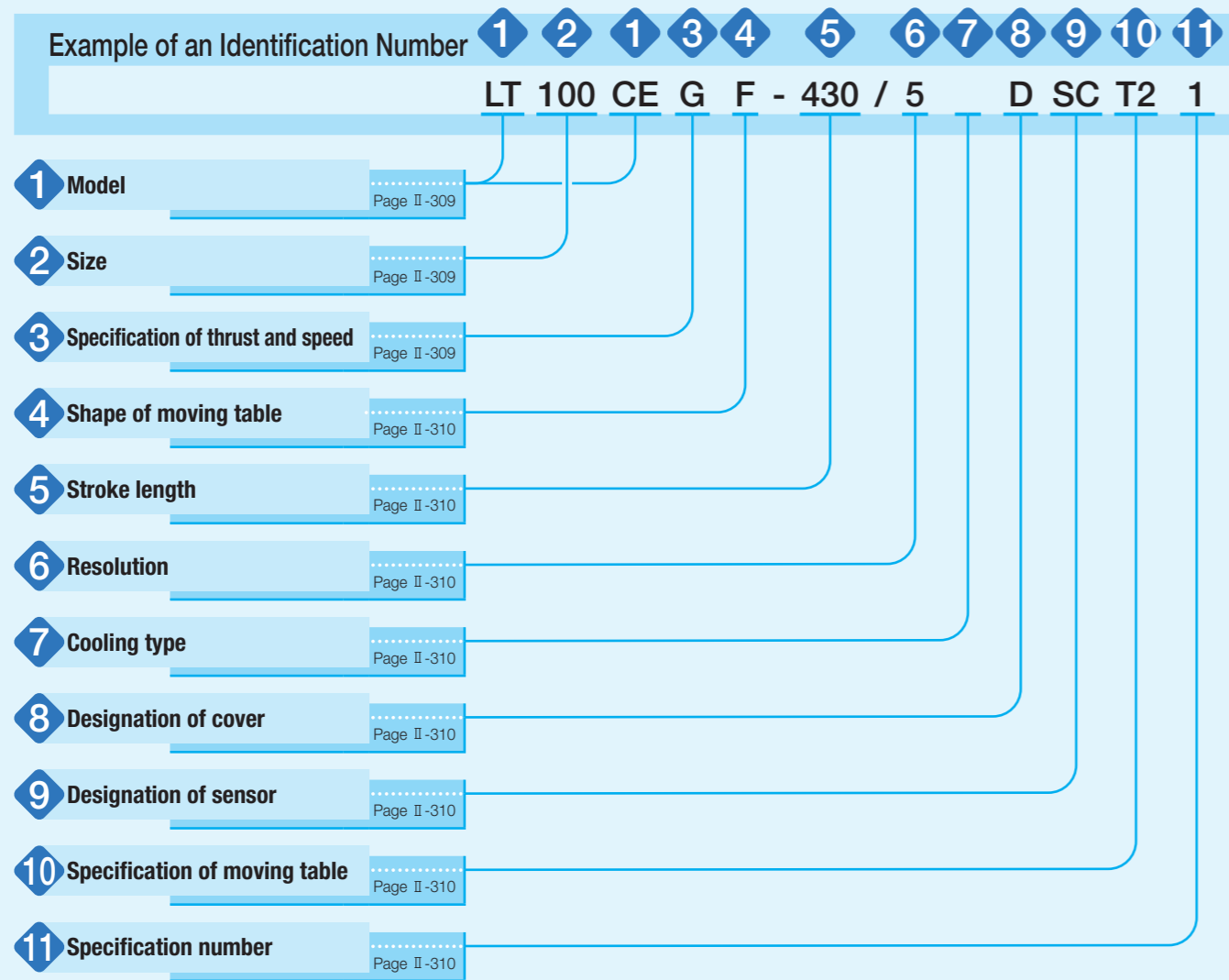

Identification Number and Specification

1 Model
 LT...CE: Linear Motor Table LT compact series
 LT...LD: Linear Motor Table LT long stroke series
 LT...H : Linear Motor Table LT high thrust series

2 Size
 100: Width 100mm (applicable to LT...CE)
 150: Width 150mm (applicable to LT...CE)
 130: Width 130mm (applicable to LT...LD)
 170: Width 170mm (applicable to LT...LD and LT...H)

3 Specification of thrust and speed
 G : High thrust (high speed) specification 1
 T : High thrust (high speed) specification 2
 V : High speed specification
 No symbol : No symbol

For application of respective specifications, please see Table 1.
 When selecting T, select F in the entry of section 4 Shape of moving table.

Table 1 Application of thrust force and speed symbols

Model	Size	Thrust / speed specification			
		G	T	V	No symbol
LT...CE	100	○	—	—	—
	150	○	○ ⁽¹⁾	—	—
LT...LD	130	○	—	—	—
	170	○	○ ⁽¹⁾	○	—
LT...H	170	—	—	—	○

Note ⁽¹⁾ Applicable only for type with flange.

Identification Number and Specification

4 Shape of moving table
 S: Standard
 F: With flange

When selecting S, set "No symbol" in the entry of section 8 "Designation of cover".
 When selecting F, select D in the entry of section 8 "Designation of cover".

5 Stroke length
 Select a stroke length from the list of Table 2.

Table 2 Stroke length

Model and size	Stroke length mm				
	LT100CEG(S, F)	200,	400,	600,	800,
LT100CEG(S, F).../T2	230,	430,	630,	830	
LT150CEG(S, F)	400,	600,	800,	1 000,	1 200
LT150CEG(S, F).../T2	350,	550,	750,	950	
LT150CETF	400,	600,	800,	1 000,	1 200
LT150CETF.../T2	350,	550,	750,	950	
LT130LDGS	240,	720,	1 200,	1 680,	2 160, 2 640, 2 760
LT130LDGS.../T2	500,	980,	1 460,	1 940,	2 420, 2 540
LT130LDGF	240,	720,	1 200,	1 680	
LT130LDGF.../T2	500,	980,	1 460		
LT170LD(G, V)S	680,	1 160,	1 640,	2 120,	2 600, 2 720
LT170LD(G, V)S.../T2	420,	900,	1 380,	1 860,	2 340, 2 460
LT170LD(G, T, V)F	680,	1 160,	1 640		
LT170LD(G, T, V)F.../T2	420,	900,	1 380		
LT170HS	650,	1 130,	1 610,	2 090,	2 570, 2 670
LT170HS...T2	410,	890,	1 370,	1 850,	2 330, 2 430
LT170HF	650,	1 130,	1 610		
LT170HF...T2	410,	890,	1 370		

6 Resolution
 1: 0.1 μm
 5: 0.5 μm
 10: 1.0 μm

7 Cooling type
 No symbol: Natural air cooling
 CA : Air cooling (applicable to LT...H)

8 Designation of cover
 No symbol: Without cover (applicable to standard moving table)
 D : With cover (applicable to moving table with flange)

9 Designation of sensor
 No symbol: Without sensor
 SC : Sensor (limit and pre-origin), with sensor rail (applicable to LT...CE)
 LT...LD and LT...H have a sensor built-in. For the entry of section 4, set "No symbol".

10 Specification of moving table
 No symbol: Single table
 T2 : Twin table

11 Specification number
 1 : Specification number 1
 The specification number is limited to 1.

Specifications

Table 3 LT···CE performance

Item	Model and size			LT100CEG			LT150CEG			LT150CETF		
Maximum thrust ⁽¹⁾	N	120			350			390				
Rated thrust	N	15			60			70				
Maximum load mass	kg	12			35			39				
Resolution	μm	0.1	0.5	1.0	0.1	0.5	1.0	0.1	0.5	1.0		
Maximum speed ⁽²⁾	mm/s	700	2 000	2 000	700	2 000	2 000	700	2 000	2 000		
Positioning repeatability ⁽³⁾	μm	±0.5	±0.5	±1.0	±0.5	±0.5	±1.0	±0.5	±0.5	±1.0		

Notes (1) The duration of maximum thrust is up to 1 second.
 (2) This maximum speed may not be reached depending on the maximum output frequency of the controller used, and the driver type or settings.
 (3) When the temperature of the product is constant.

Table 4 LT···LD performance

Item	Model and size			LT130LDG			LT170LDG			LT170LDV			LT170LDTF		
Maximum thrust ⁽¹⁾	N	120			350			145			390				
Rated thrust	N	15			60			25			70				
Maximum load mass	kg	12			35			20			39				
Resolution	μm	0.1	0.5	1.0	0.1	0.5	1.0	0.1	0.5	1.0	0.1	0.5	1.0		
Maximum speed ⁽²⁾	mm/s	700	2 000	3 000	700	2 000	2 000	700	2 000	3 000	700	2 000	2 000		
Positioning repeatability ⁽³⁾	μm	±0.5	±0.5	±1.0	±0.5	±0.5	±1.0	±0.5	±0.5	±1.0	±0.5	±0.5	±1.0		

Notes (1) The duration of maximum thrust is up to 1 second.
 (2) This maximum speed may not be reached depending on the maximum output frequency of the controller used, and the driver type or settings.
 (3) When the temperature of the product is constant.

Table 5 LT···H performance

Item	Model and size			LT170H			
Maximum thrust ⁽¹⁾	N	900					
Rated thrust ⁽²⁾	Natural air cooling	N			120		
	Air cooling ⁽³⁾	N			150		
Maximum load mass	kg	90					
Resolution	μm	0.1	0.5	1.0			
Maximum speed ⁽⁴⁾ ⁽⁵⁾	mm/s	700	1 500(2 000)	1 500(2 000)			
Positioning repeatability ⁽⁶⁾	μm	±0.5	±0.5	±1.0			

Notes (1) The duration of maximum thrust is up to 1 second.
 (2) In the case where the unit is fixed on a steel-made cradle under ambient temperature of 0 to 25°C. For more information, please see Fig. 12 on page II-314.
 (3) This is under air flow rate of 30NL/min.
 (4) For the speed exceeding 1,500mm/s, please contact IKO.
 (5) This maximum speed may not be reached depending on the maximum output frequency of the controller used, and the driver type or settings.
 (6) When the temperature of the product is constant.

Thrust characteristics of LT···CE

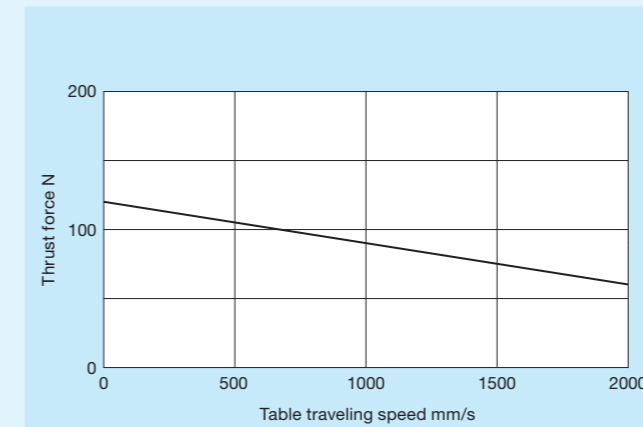

Fig. 1 Thrust characteristics of LT100CEG

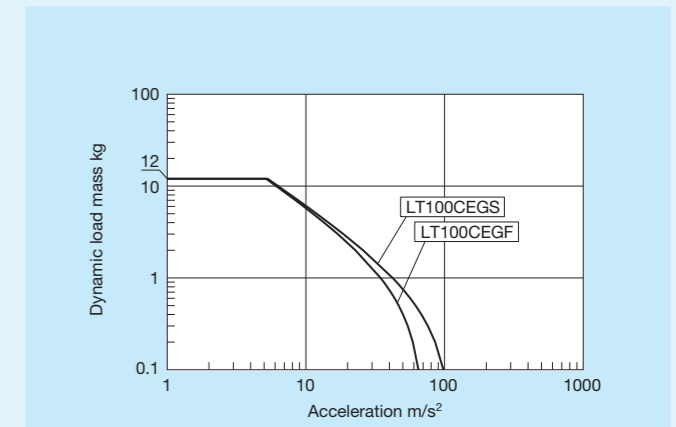

Fig. 2 Dynamic load mass of LT100CEG

Remark: These are values calculated based on the thrust force with table moving speed set to 1,000mm/s.

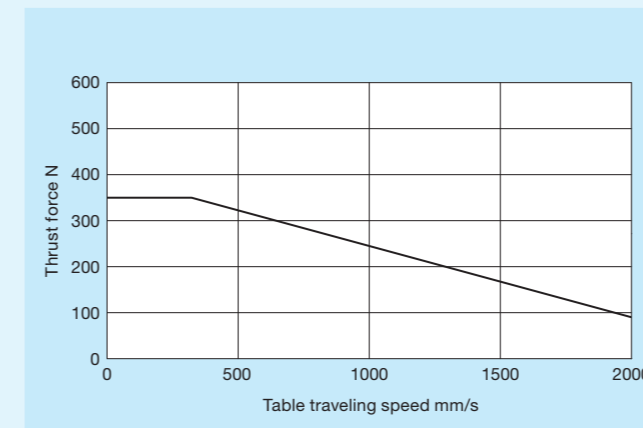

Fig. 3 Thrust characteristics of LT150CEG

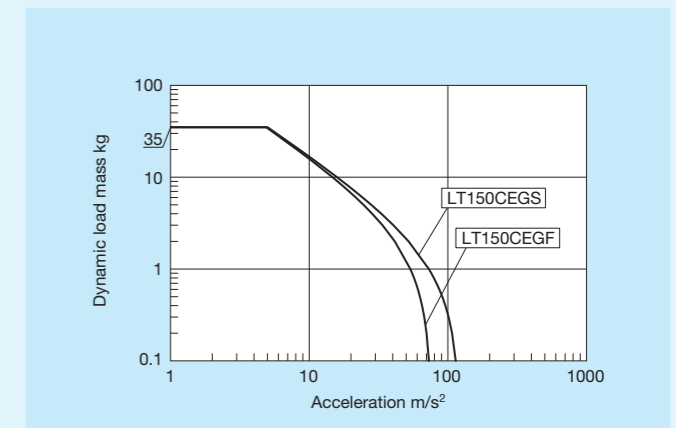

Fig. 4 Dynamic load mass of LT150CEG

Remark: These are values calculated based on the thrust force with table moving speed set to 1,000mm/s.

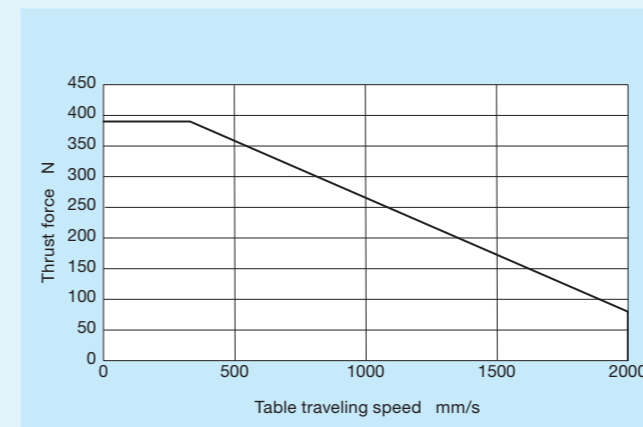

Fig. 5 Thrust characteristics of LT150CETF

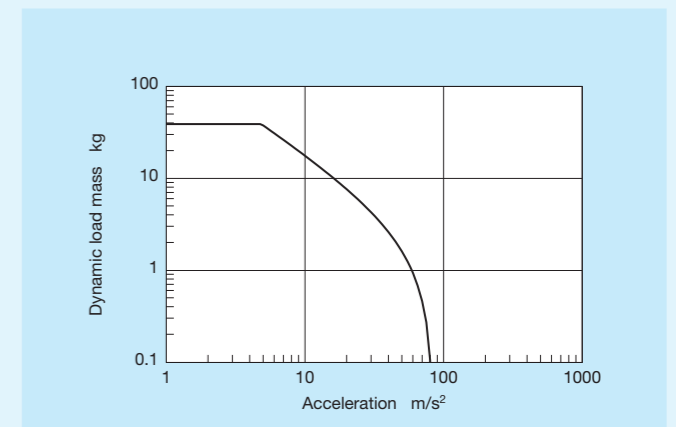
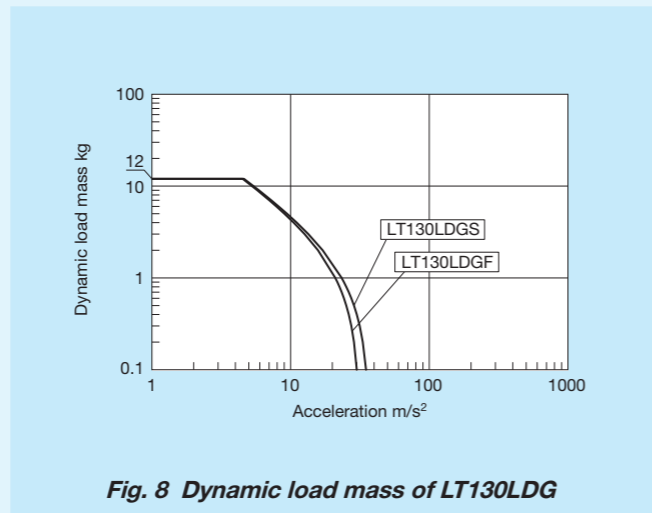
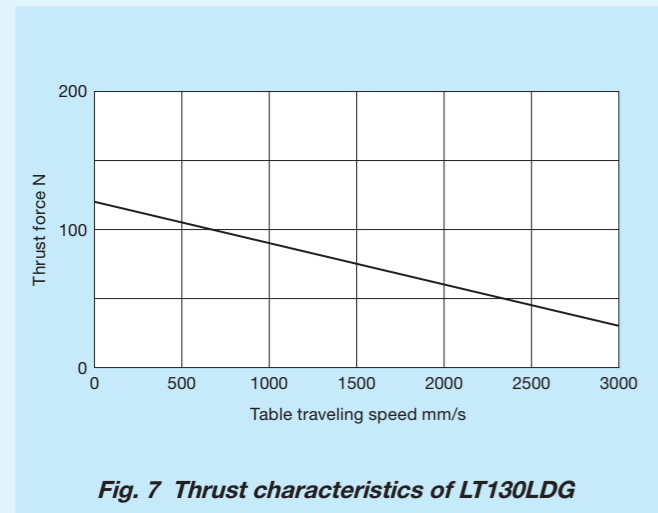

Fig. 6 Dynamic load mass of LT150CETF

Remark: These are values calculated based on the thrust force with table moving speed set to 1,000mm/s.

■ Thrust characteristics of LT···LD



Remark: These are values calculated based on the thrust force with table moving speed set to 1,000mm/s.

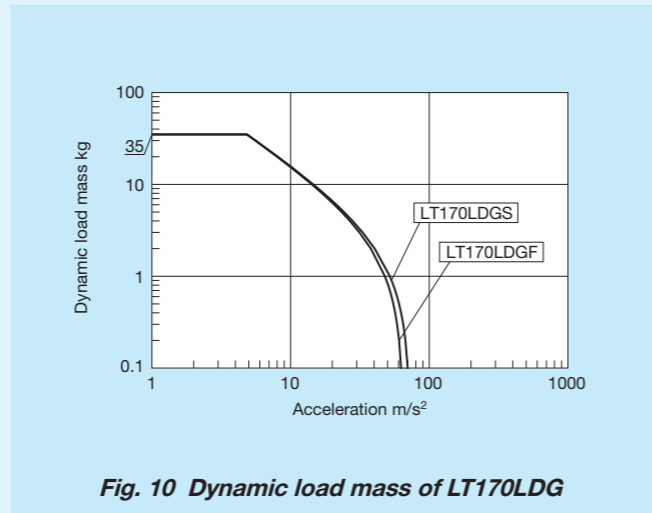
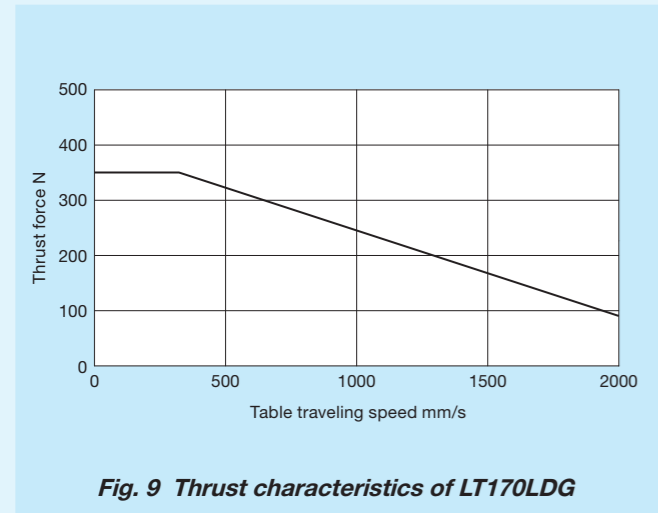

Remark: These are values calculated based on the thrust force with table moving speed set to 1,000mm/s.

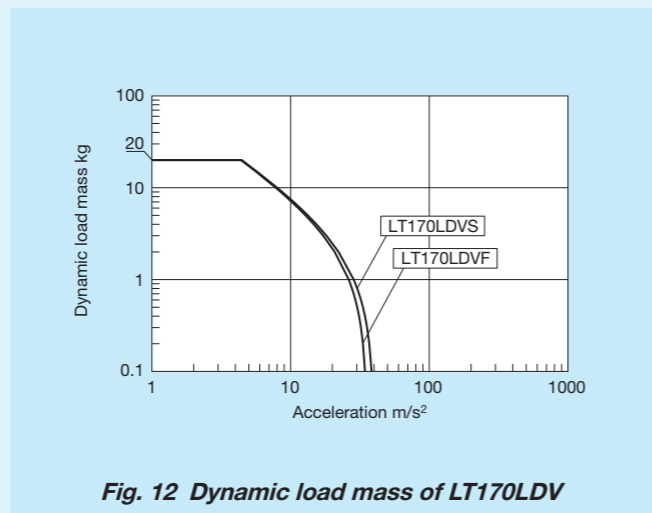
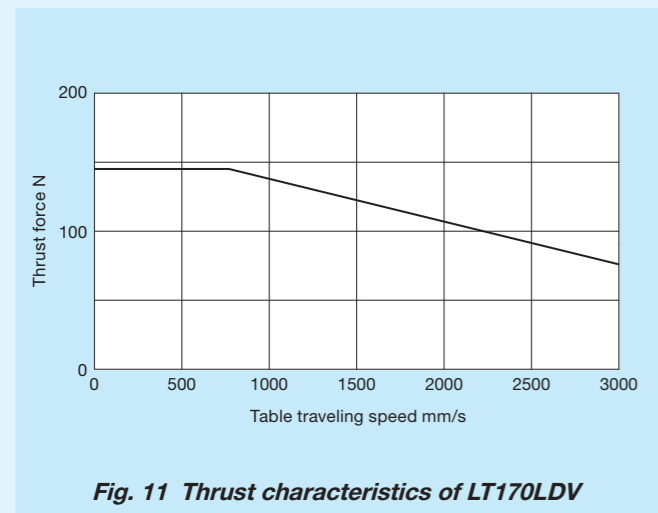

Remark: These are values calculated based on the thrust force with table moving speed set to 1,000mm/s.

■ Thrust characteristics of LT···LD

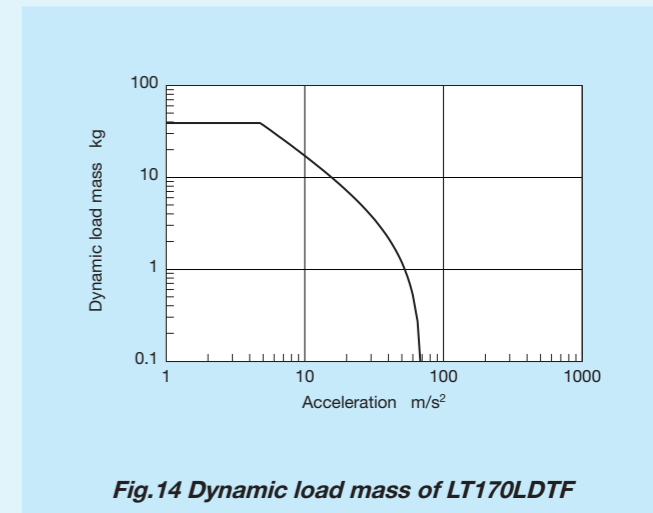
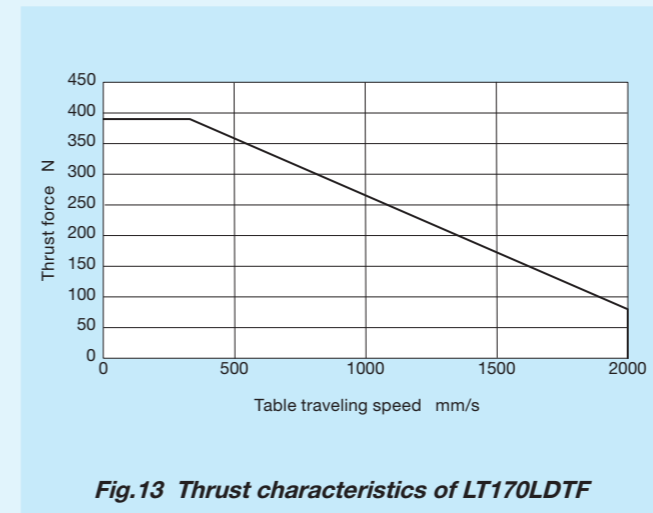

Remark: These are values calculated based on the thrust force with table moving speed set to 1,000mm/s.

■ Thrust characteristics of LT···H

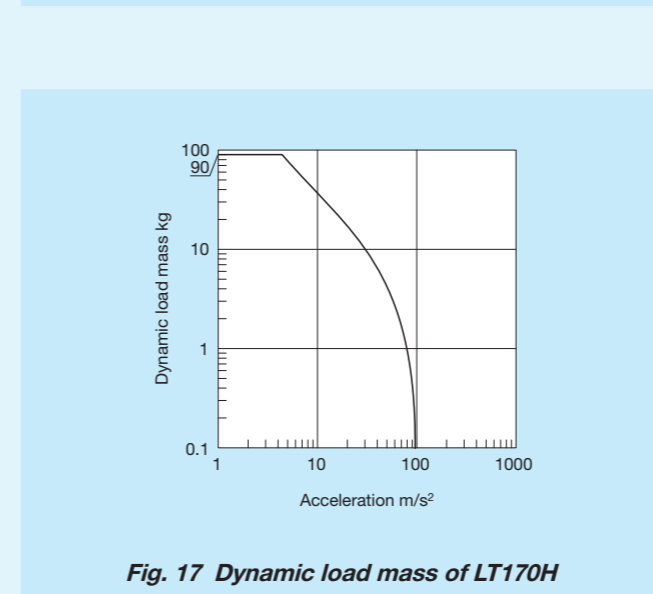
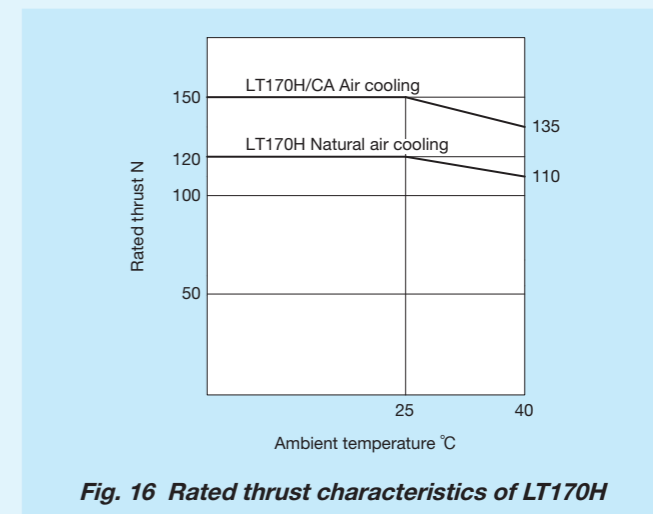
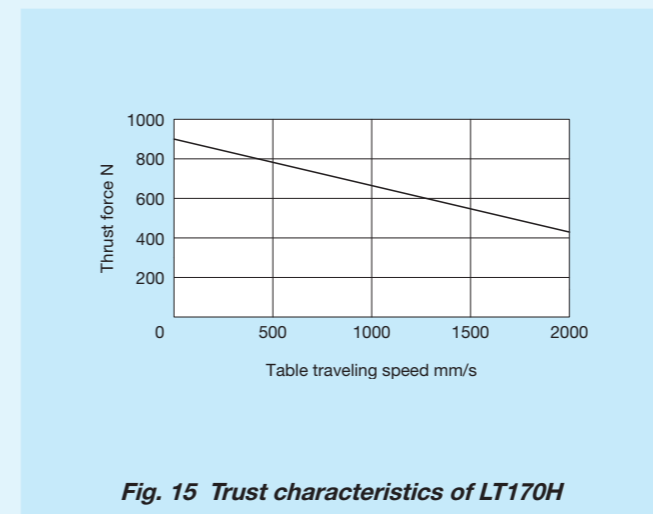

Remark: These are values calculated based on the thrust force with table moving speed set to 1,000mm/s.

Mounting

For the processing accuracy of the Precision Positioning Table mounting surface and the tightening torque of the fixing screws, see page III-30.

Sensor Specification

Table 6.1 Sensor timing chart for single table of LT...CE, LT...LD, and LT...H

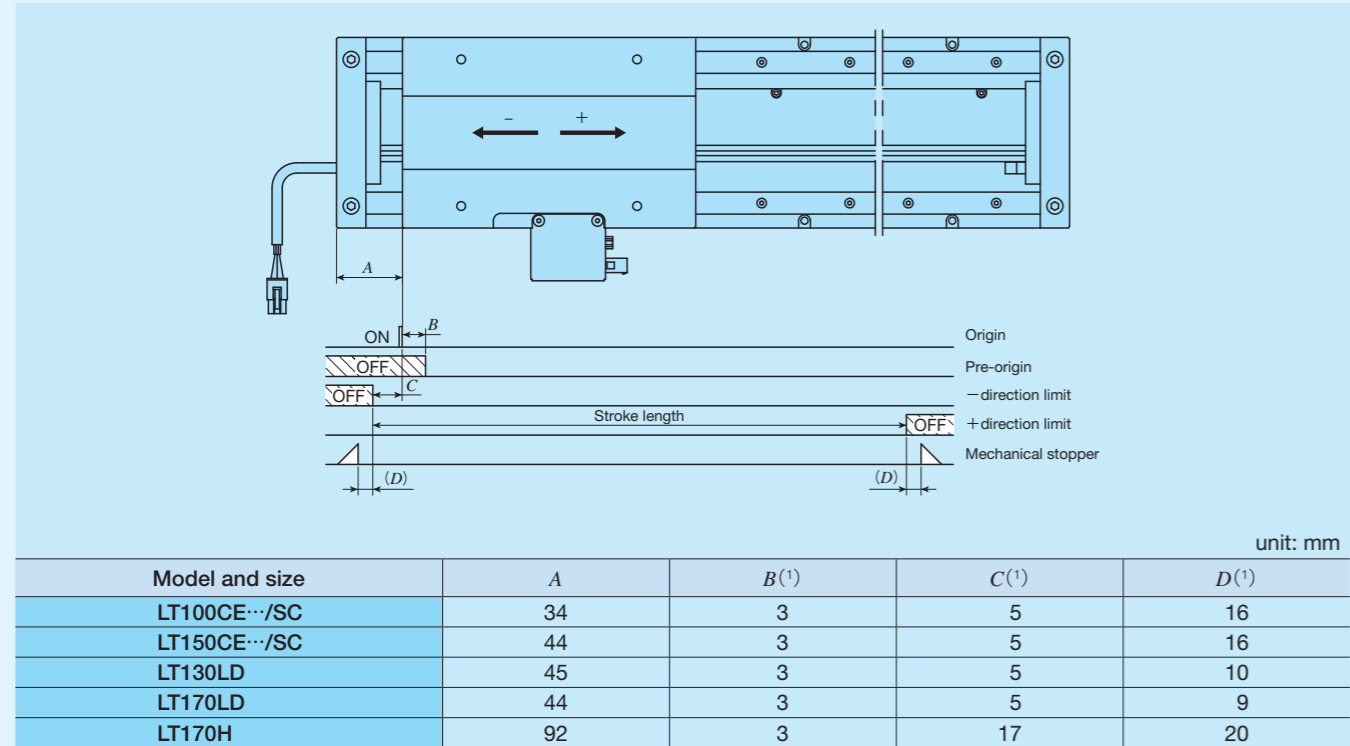

Note ⁽¹⁾ Respective values are for reference and are not guaranteed values. For detailed dimensions, please contact IKO.
Remark: For the specifications of respective sensors, please see the section of sensor specification in General Explanation.

Table 6.2 Sensor timing chart for twin tables of LT...CE, LT...LD, and LT...H

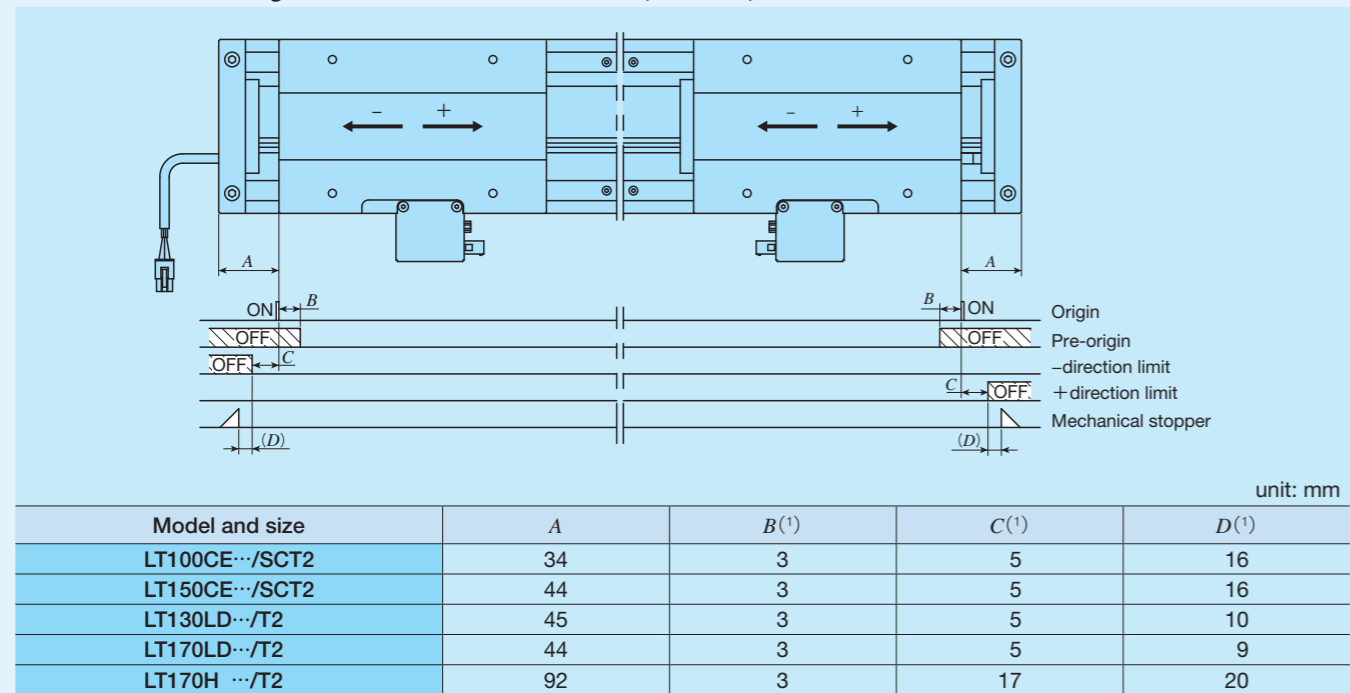

Note ⁽¹⁾ Respective values are for reference and are not guaranteed values. For detailed dimensions, please contact IKO.
Remark: For the specifications of respective sensors, please see the section of sensor specification in General Explanation.

System Configuration

ADVA is available as a dedicated driver for Linear Motor Table LT; for its system configuration there are two available specification types, pulse train specification and high speed network EtherCAT specification. Table 7 shows an example of identification number for ADVA, and Table 8 shows its system configuration. For detailed ADVA specifications, see the driver specifications on pages II-383 to II-384.

Please also note that the driver (MR-J4-10B made by Mitsubishi Electric Corporation) compatible with SSCNET III/H and that compatible with MECHATROLINK (Σ-7 Series AC servo amplifier made by Yaskawa Electric Corporation) will be prepared based on usage. If needed, please contact IKO.

Table 7 Identification number for ADVA

ADVA	-	01NL	EC	/	LT100CEG
(1) Model	(2)	(3)	(4)		
(2) Power supply voltage/maximum applicable motor capacity					
01NL	Single-phase / Three-phase 200 V, 100 W (Applicable to LT...CE, LT...LD)				
08NL	Single-phase / Three-phase 200 V, 750 W (Applicable to LT170H)				
(3) Command type					
No symbol	Pulse train command				
EC	EtherCAT				
(4) Applicable Linear Motor Table model					
LT100CEG	LT100CEG				
LT150CEG	LT150CEG (high thrust specification 1)				
LT150CET	LT150CET (high thrust specification 2)				
LT130LDG	LT130LDG				
LT170LDG	LT170LDG (high thrust specification 1)				
LT170LDT	LT170LDT (high thrust specification 2)				
LT170LDV	LT170LDV (high speed specification)				
LT170H	LT170H				

● Setup Software

When operating Linear Motor Table LT through ADVA, initial setting of driver parameters is required. Parameter setting for driver is performed using the setup software. It can also be used for gain adjustment and operational status check. In the driver, the setup software and PC connection cable are not provided. These can be shared in plural drivers but at least 1 set is required. Please prepare these on your own or place an order separately according to your requirement.

● Motion Network

The ADVA driver for Linear Motor Drive Table LT supports motion network EtherCAT. Motion network realizes higher performance and higher accuracy of devices free from pulse frequency constraint in pulse train command, noise effects in analog command (voltage command), voltage drop due to cable length and effects of temperature drifting. Reduction of wiring can also be achieved, so synchronization system with more than one table can easily be established.

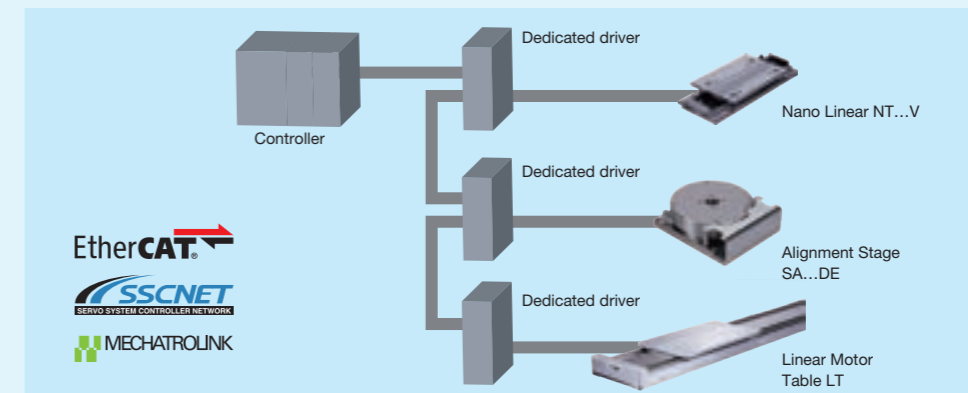

Remark: Please also note that the driver (MR-J4-10B made by Mitsubishi Electric Corporation) compatible with SSCNET III/H and that compatible with MECHATROLINK (Σ-7 Series AC servo amplifier made by Yaskawa Electric Corporation) will be prepared based on usage. If needed, please contact IKO.

Model	Features
EtherCAT	This is an Ethernet-based open network communication system developed by Beckhoff of Germany, allowing real time control. High speed communication and high accuracy inter-node synchronization provide higher performance and higher accuracy of devices. In addition, Ethernet cables available on the market can be used and various wiring types can be supported.
SSCNET III/H	This is a motion network communication system for servo system control developed by Mitsubishi Electric Corporation. It applies the optical fiber cables, so noise immunity is improved relative to conventional SSCNET.
MECHATROLINK	The open field network communication that connects the controller and various components. Developed by Yaskawa Electric Corporation and managed by MECHATROLINK Members Association.

Table 8 System configuration for LT with driver ADVA (…EC)

● Example of system configuration for single table

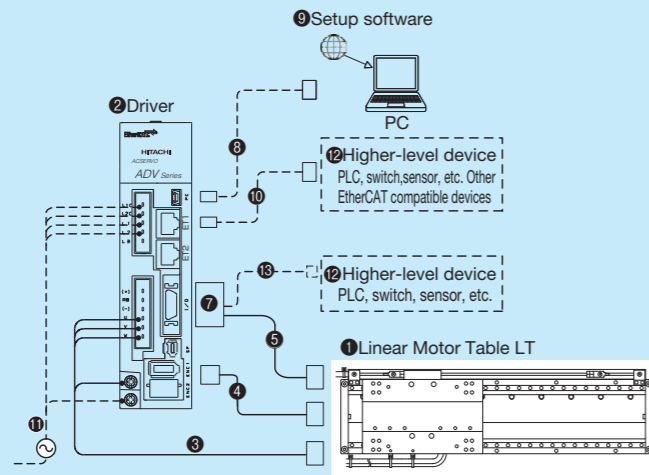

● Example of system configuration for twin table

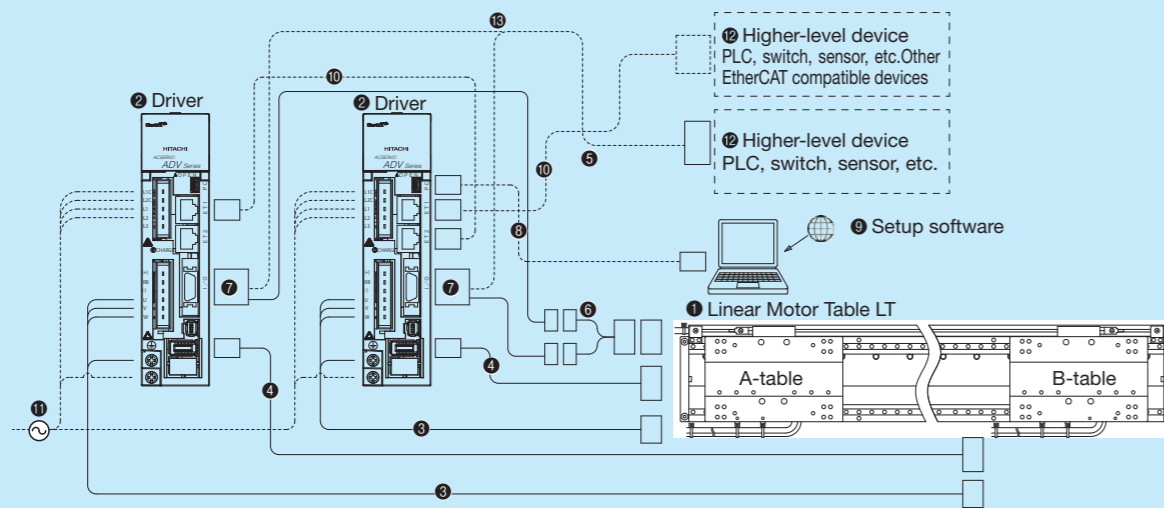

No.	Name	Identification number
1	Linear motor table	Please see pages of II-318 to II-328.
2	Driver	Please see Table 7 to select suitable driver for Linear Motor Table model.
3	Motor extension cord	TAE20V7-AM□□ (applicable to LT…CE, LT…LD) TAE20V9-AM□□ (applicable to LT…H)
4	Encoder extension cord	TAE20V8-EC□□ (applicable to LT…CE, LT…LD) TAE20W0-EC□□ (applicable to LT…H)
5	Sensor extension cord (3)	TAE10V8-LC□□
6	Limit branch cord (0.1m)	TAE20V2-BC
7	I/O connector	TAE20R5-CN(1) (applicable to driver for pulse train command) TAE20V5-CN(2) (applicable to driver for EtherCAT)
8	PC connection cable	USB mini B cable This must be prepared by customer.
9	Setup software	ProDriveNext Please download from the official website of Hitachi Industrial Equipment Systems Co., Ltd.
10	Ethernet cable	This must be prepared by customer.
11	Power cord	
12	Higher-level device	
13	I/O connector connection cable	

Note (1) I/O connector TAE20R5-CN is a combined product of 10150-3000PE (connector) and 10350-52F0-008 (cover) from 3M Japan Limited.

(2) I/O connector TAE20V5-CN is a combined product of 10120-3000PE (connector) and 10320-52F0-008 (cover) from 3M Japan Limited.

(3) Signal lines #9 and #11 of the sensor extension cord for the B-table are not in use.

Remark The lengths of motor extension cord, encoder extension cord, and sensor extension cord are specified in the □□ located at the end of the identification number for length of 3 to 10m in units of 1m.

The cord length is specified in two digits even when the length is less than 10m. (For 3m: TAE20V7-AM03)

IKO Linear Motor Table LT

LT100CEGS Single table

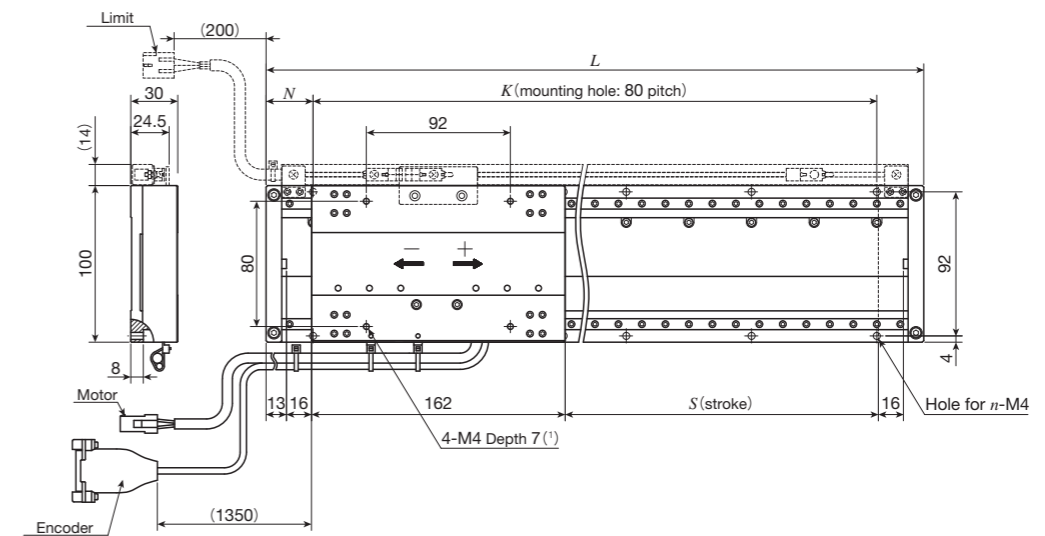

unit: mm

Identification number	Stroke length $S^{(2)}$	Overall length L	Mounting holes of bed			Total mass of table kg	Mass of moving table kg
			N	K	n		
LT100CEGS- 200	200	420	50	320	10	0.58	
LT100CEGS- 400	400	620	30	560	16		
LT100CEGS- 600	600	820	50	720	20		
LT100CEGS- 800	800	1 020	30	960	26		
LT100CEGS-1000	1 000	1 220	50	1 120	30		

Notes (1) Too deep insertion depth of the mounting bolt may affect the running performance of the moving table, so never insert a bolt longer than the depth of the through hole.

(2) For other stroke lengths, please contact IKO.

Remark: Dashed line portions in the dimensional figures indicate the sensor-included specification / SC.

LT100CEGS/T2 Twin table

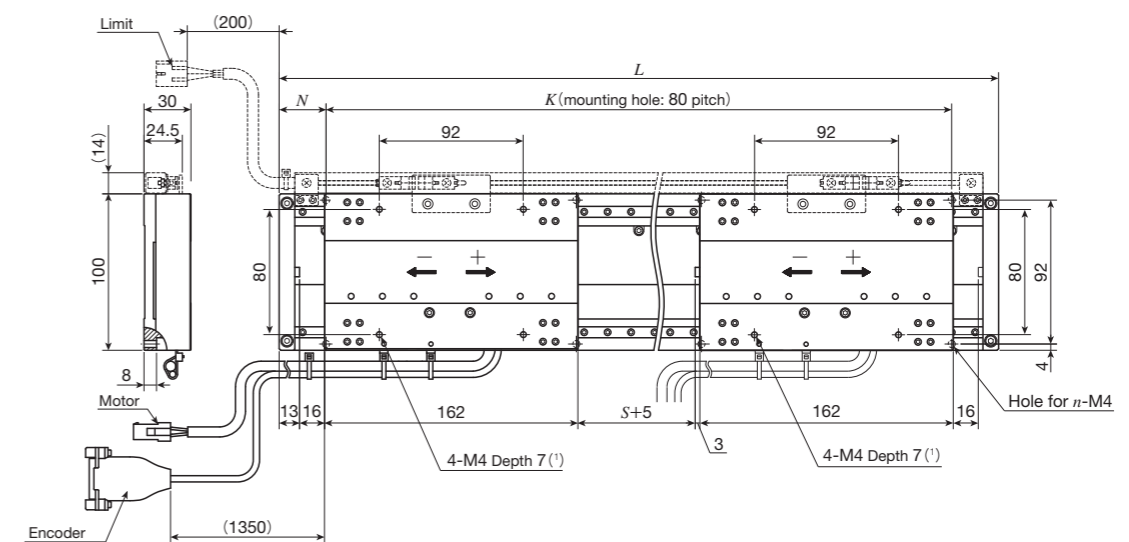

unit: mm

Identification number	Stroke length $S^{(2)}$	Overall length L	Mounting holes of bed			Total mass of table kg	Mass of moving table kg
			N	K	n		
LT100CEGS-230/T2	230	620	30	560	16	0.58	
LT100CEGS-430/T2	430	820	50	720	20		
LT100CEGS-630/T2	630	1 020	30	960	26		
LT100CEGS-830/T2	830	1 220	50	1 120	30		

Notes (1) Too deep insertion depth of the mounting bolt may affect the running performance of the moving table, so never insert a bolt longer than the depth of the through hole.

(2) For other stroke lengths, please contact IKO.

Remark: Dashed line portions in the dimensional figures indicate the sensor-included specification / SC.

IKO Linear Motor Table LT

LT100CEGF/D Single table with cover

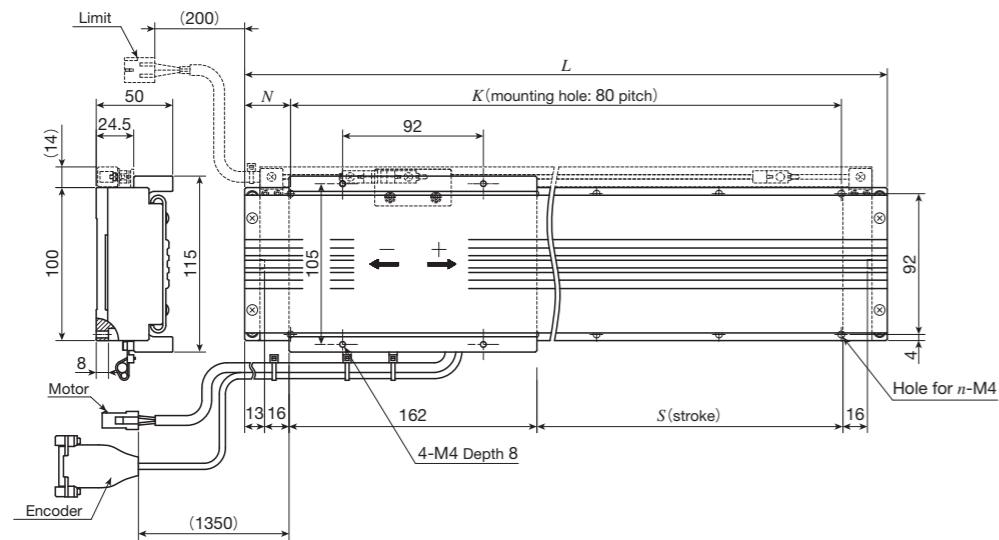

unit: mm

Identification number	Stroke length $S^{(1)}$	Overall length L	Mounting holes of bed			Total mass of table kg	Mass of moving table kg
			N	K	n		
LT100CEGF- 200/D	200	420	50	320	10	5.6	0.93
LT100CEGF- 400/D	400	620	30	560	16	7.8	
LT100CEGF- 600/D	600	820	50	720	20	10.0	
LT100CEGF- 800/D	800	1 020	30	960	26	12.2	
LT100CEGF-1000/D	1 000	1 220	50	1 120	30	14.4	

Note (1) For other stroke lengths, please contact IKO.

Remark: Dashed line portions in the dimensional figures indicate the sensor-included specification / SC.

LT100CEGF/DT2 Twin table with cover

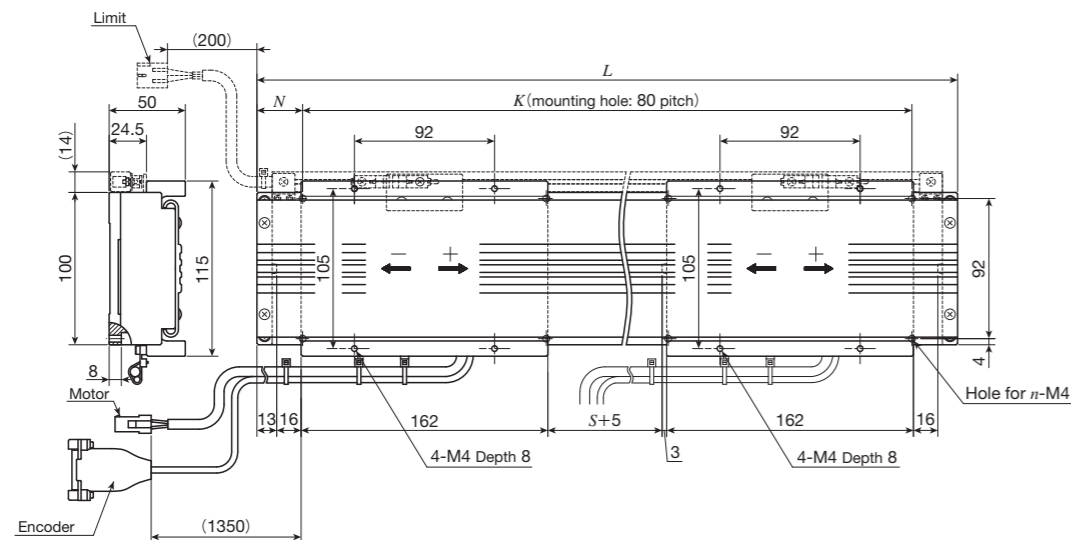

unit: mm

Identification number	Stroke length $S^{(1)}$	Overall length L	Mounting holes of bed			Total mass of table kg	Mass of moving table kg
			N	K	n		
LT100CEGF-230/DT2	230	620	30	560	16	8.7	0.93
LT100CEGF-430/DT2	430	820	50	720	20	10.9	
LT100CEGF-630/DT2	630	1 020	30	960	26	13.2	
LT100CEGF-830/DT2	830	1 220	50	1 120	30	15.4	

Note (1) For other stroke lengths, please contact IKO.

Remark: Dashed line portions in the dimensional figures indicate the sensor-included specification / SC.

LT150CEGS Single table

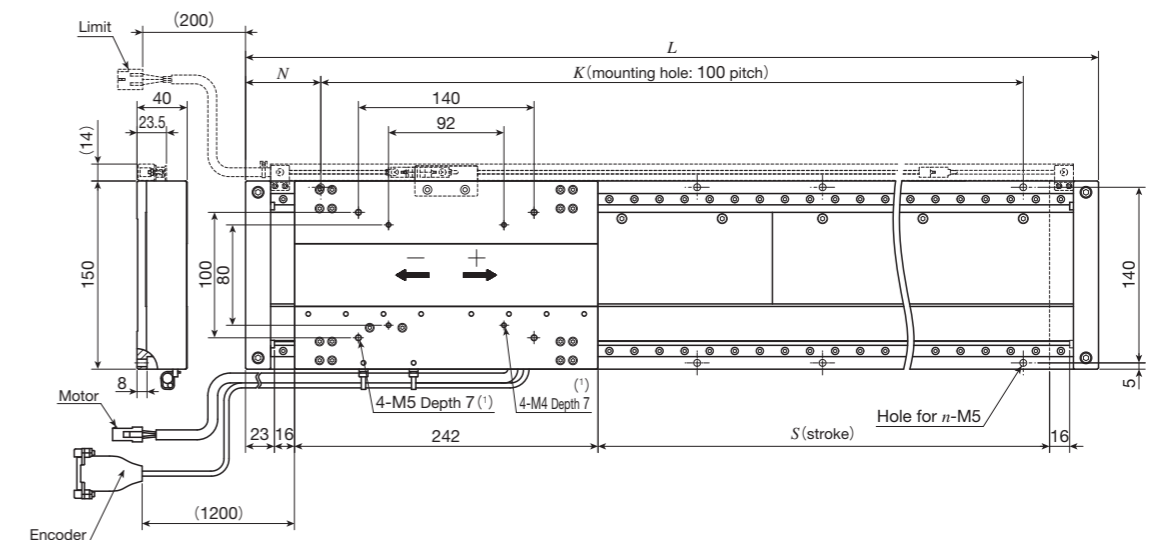

unit: mm

Identification number	Stroke length $S^{(2)}$	Overall length L	Mounting holes of bed			Total mass of table kg	Mass of moving table kg
			N	K	n		
LT150CEGS- 400	400	720	60	600	14	12.4	1.5
LT150CEGS- 600	600	920	60	800	18	15.5	
LT150CEGS- 800	800	1 120	60	1 000	22	18.6	
LT150CEGS-1000	1 000	1 320	60	1 200	26	21.6	
LT150CEGS-1200	1 200	1 520	60	1 400	30	24.7	

Notes (1) Too deep insertion depth of the mounting bolt may affect the running performance of the moving table, so never insert a bolt longer than the depth of the through hole.

(2) For other stroke lengths, please contact IKO.

Remark: Dashed line portions in the dimensional figures indicate the sensor-included specification / SC.

LT150CEGS/T2 Twin table

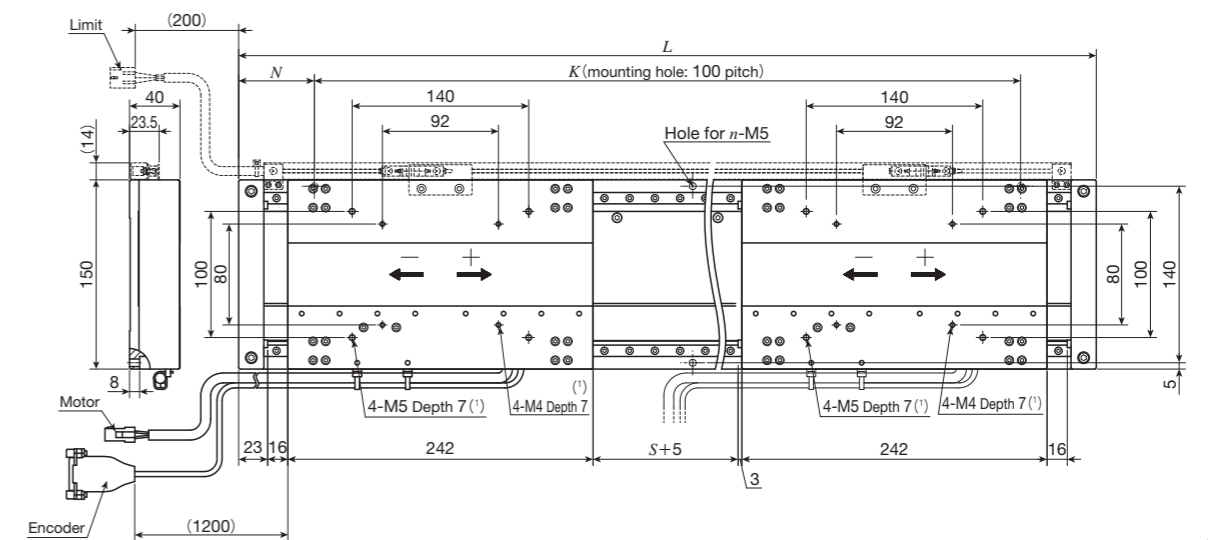

unit: mm

Identification number	Stroke length $S^{(2)}$	Overall length L	Mounting holes of bed			Total mass of table kg	Mass of moving table kg
			N	K	n		
LT150CEGS-350/T2	350	920	60	800	18	17.0	1.5
LT150CEGS-550/T2	550	1 120	60	1 000	22	20.1	
LT150CEGS-750/T2	750	1 320	60	1 200	26	23.1	
LT150CEGS-950/T2	950	1 520	60	1 400	30	26.2	

Notes (1) Too deep insertion depth of the mounting bolt may affect the running performance of the moving table, so never insert a bolt longer than the depth of the through hole.

(2) For other stroke lengths, please contact IKO.

Remark: Dashed line portions in the dimensional figures indicate the sensor-included specification / SC.

1N=0.102kgf=0.2248lbs.
1mm=0.03937inch

IKO Linear Motor Table LT

LT150CEGF/D Single table with cover / High thrust specification 1
 LT150CETF/D Single table with cover / High thrust specification 2

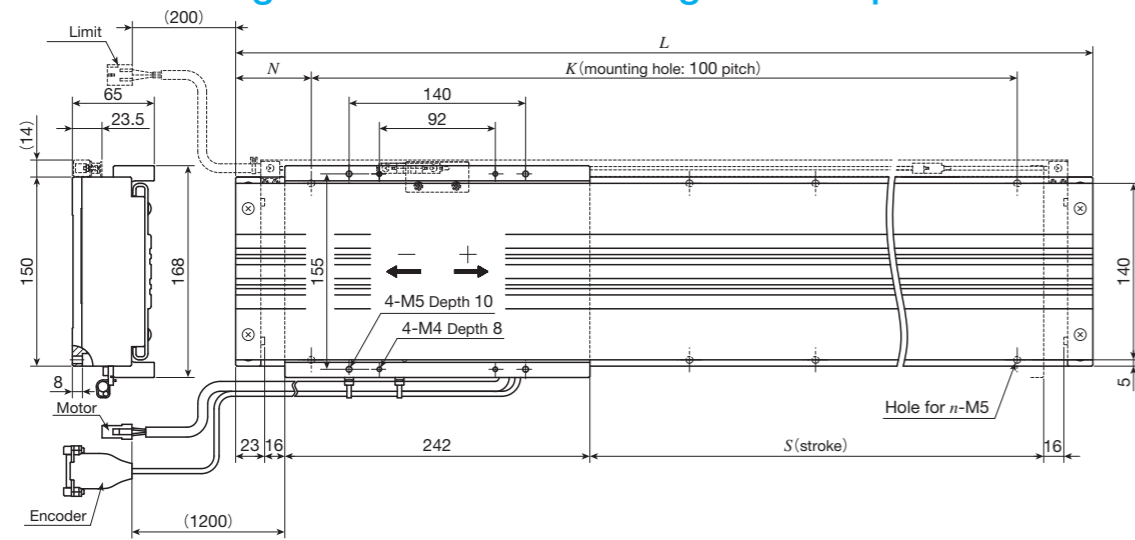

Identification number	Stroke length $S^{(1)}$	Overall length L	Mounting holes of bed			Total mass of table kg	Mass of moving table kg
			N	K	n		
LT150CEGF- 400/D	400	720	60	600	14	14.8	2.4
LT150CEGF- 600/D	600	920	60	800	18	18.1	
LT150CEGF- 800/D	800	1 120	60	1 000	22	21.5	
LT150CEGF-1000/D	1 000	1 320	60	1 200	26	24.8	
LT150CEGF-1200/D	1 200	1 520	60	1 400	30	28.2	
LT150CETF- 400/D	400	720	60	600	14	15.3	
LT150CETF- 600/D	600	920	60	800	18	18.7	
LT150CETF- 800/D	800	1 120	60	1 000	22	22.5	
LT150CETF-1000/D	1 000	1 320	60	1 200	26	25.7	
LT150CETF-1200/D	1 200	1 520	60	1 400	30	29.2	

Note (1) For other stroke lengths, please contact IKO.
 Remark: Dashed line portions in the dimensional figures indicate the sensor-included specification / SC.

LT150CEGF/DT2 Twin table with cover / High thrust specification 1
 LT150CETF/DT2 Twin table with cover / High thrust specification 2

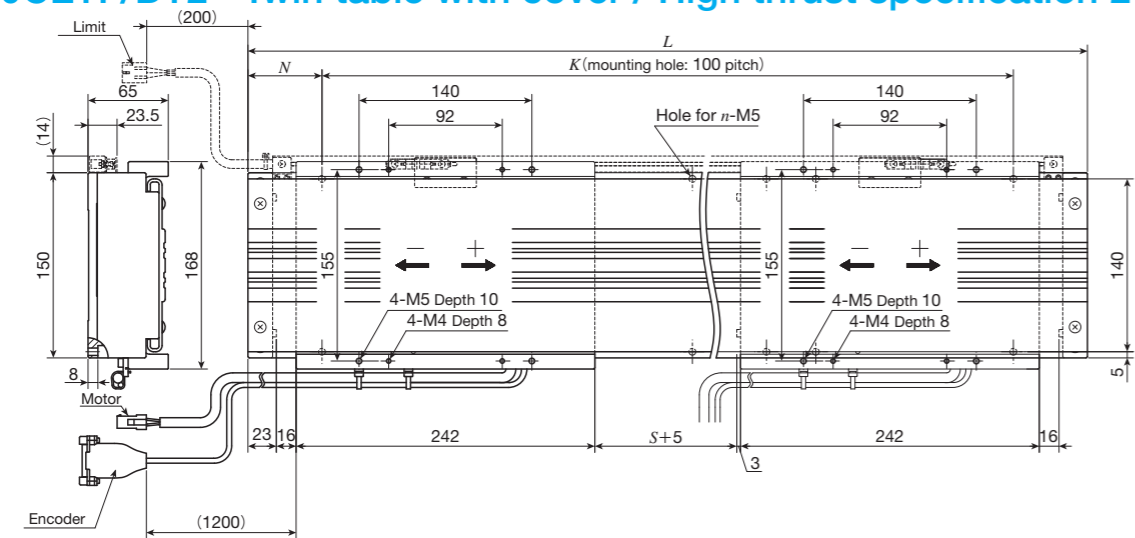

Identification number	Stroke length $S^{(1)}$	Overall length L	Mounting holes of bed			Total mass of table kg	Mass of moving table kg
			N	K	n		
LT150CEGF-350/DT2	350	920	60	800	18	20.5	2.4
LT150CEGF-550/DT2	550	1 120	60	1 000	22	23.9	
LT150CEGF-750/DT2	750	1 320	60	1 200	26	27.3	
LT150CEGF-950/DT2	950	1 520	60	1 400	30	30.6	
LT150CETF-350/DT2	350	920	60	800	21	20.5	
LT150CETF-550/DT2	550	1 120	60	1 000	24.5	23.9	
LT150CETF-750/DT2	750	1 320	60	1 200	28	27.3	
LT150CETF-950/DT2	950	1 520	60	1 400	31.5	30.6	

Note (1) For other stroke lengths, please contact IKO.
 Remark: Dashed line portions in the dimensional figures indicate the sensor-included specification / SC.

LT130LDGS Single table

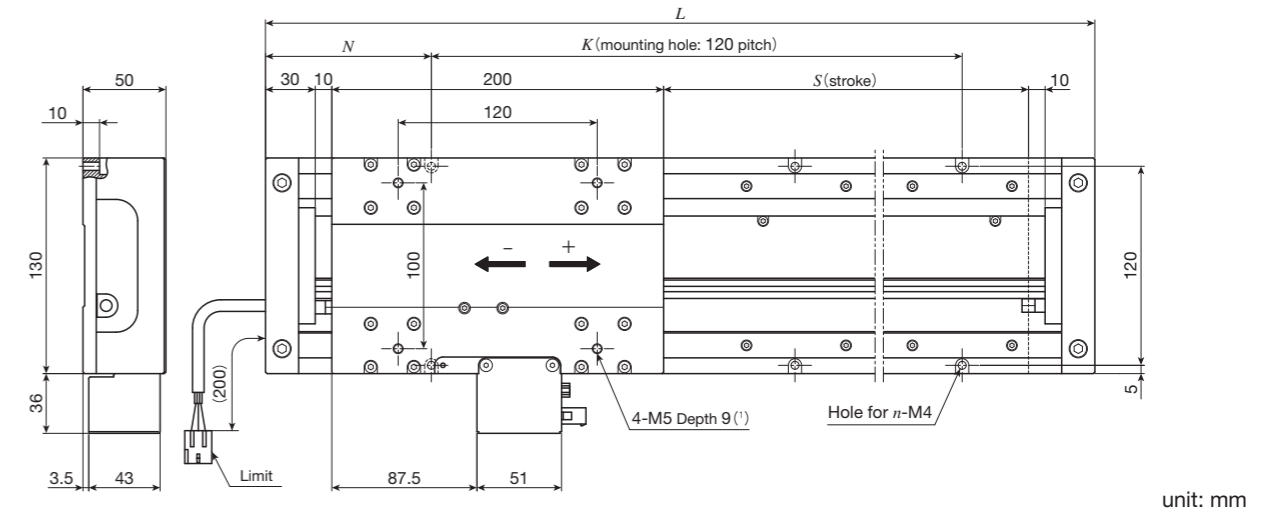

Identification number	Stroke length $S^{(2)}$	Overall length L	Mounting holes of bed			Total mass of table kg	Mass of moving table kg
			N	K	n		
LT130LDGS- 240	240	520	80	360	8	7.6	1.7
LT130LDGS- 720	720	1 000	80	840	16	13.5	
LT130LDGS-1200	1 200	1 480	80	1320	24	19.4	
LT130LDGS-1680	1 680	1 960	80	1800	32	25.3	
LT130LDGS-2160	2 160	2 440	80	2280	40	31.2	
LT130LDGS-2640	2 640	2 920	80	2760	48	37.1	
LT130LDGS-2760	2 760	3 040	80	2880	50	38.6	

Notes (1) Too deep insertion depth of the mounting bolt may affect the running performance of the moving table, so never insert a bolt longer than the depth of the through hole.
 (2) For other stroke lengths, please contact IKO.

LT130LDGS/T2 Twin table

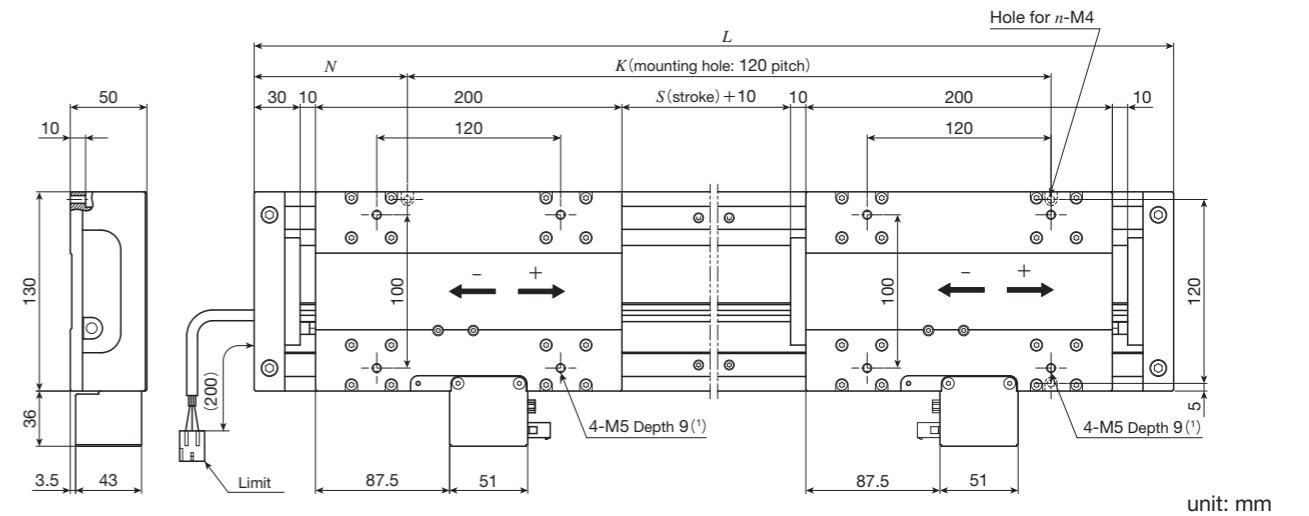

Identification number	Stroke length $S^{(2)}$	Overall length L	Mounting holes of bed			Total mass of table kg	Mass of moving table kg
			N	K	n		
LT130LDGS- 500/T2	500	1 000	80	840	16	15.2	1.7
LT130LDGS- 980/T2	980	1 480	80	1 320	24	21.1	
LT130LDGS-1460/T2	1 460	1 960	80	1 800	32	27.0	
LT130LDGS-1940/T2	1 940	2 440	80	2 280	40	32.9	
LT130LDGS-2420/T2	2 420	2 920	80	2 760	48	38.8	
LT130LDGS-2540/T2	2 540	3 040	80	2 880	50	40.3	

Notes (1) Too deep insertion depth of the mounting bolt may affect the running performance of the moving table, so never insert a bolt longer than the depth of the through hole.
 (2) For other stroke lengths, please contact IKO.

IKO Linear Motor Table LT

LT130LDGF/D Single table with cover

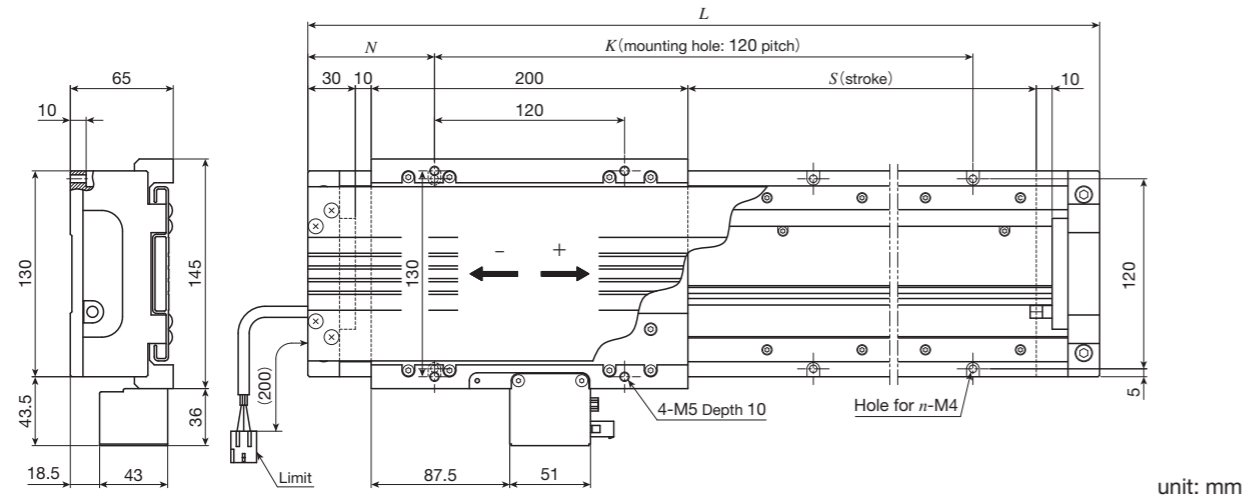

Identification number	Stroke length $S^{(1)}$	Overall length L	Mounting holes of bed			Total mass of table kg	Mass of moving table kg
			N	K	n		
LT130LDGF- 240/D	240	520	80	360	8	8.3	2.0
LT130LDGF- 720/D	720	1 000	80	840	16	14.6	
LT130LDGF-1200/D	1 200	1 480	80	1 320	24	20.9	
LT130LDGF-1680/D	1 680	1 960	80	1 800	32	27.2	

Note (1) For other stroke lengths, please contact IKO.

LT130LDGF/DT2 Twin table with cover

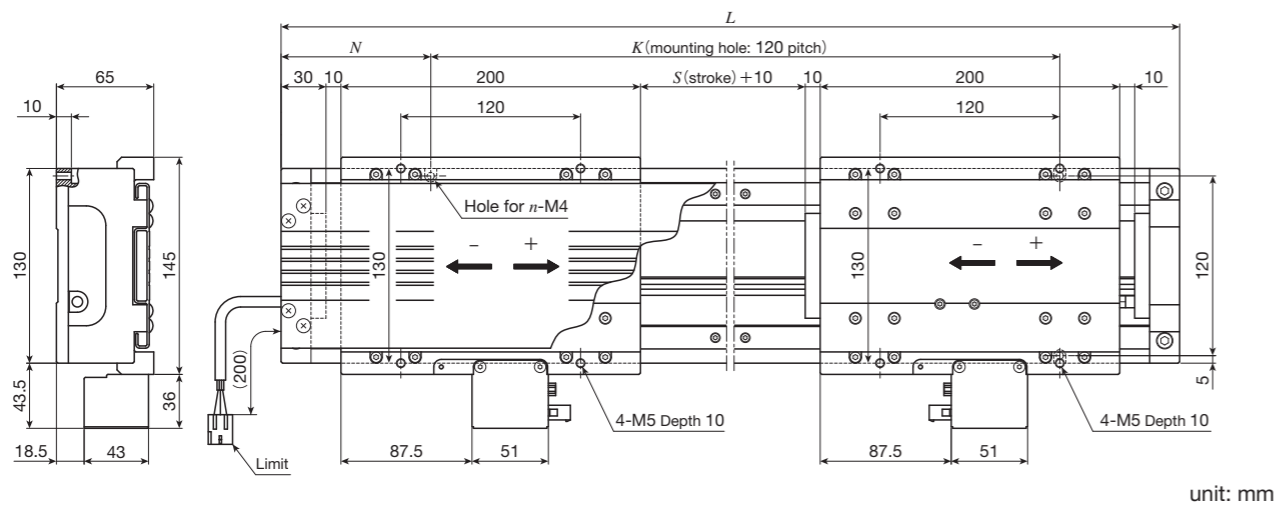

Identification number	Stroke length $S^{(1)}$	Overall length L	Mounting holes of bed			Total mass of table kg	Mass of moving table kg
			N	K	n		
LT130LDGF- 500/DT2	500	1 000	80	840	16	16.6	2.0
LT130LDGF- 980/DT2	980	1 480	80	1 320	24	22.8	
LT130LDGF-1460/DT2	1 460	1 960	80	1 800	32	29.1	

Note (1) For other stroke lengths, please contact IKO.

LT170LDGS Single table / High thrust specification LT170LDVS Single table / High speed specification

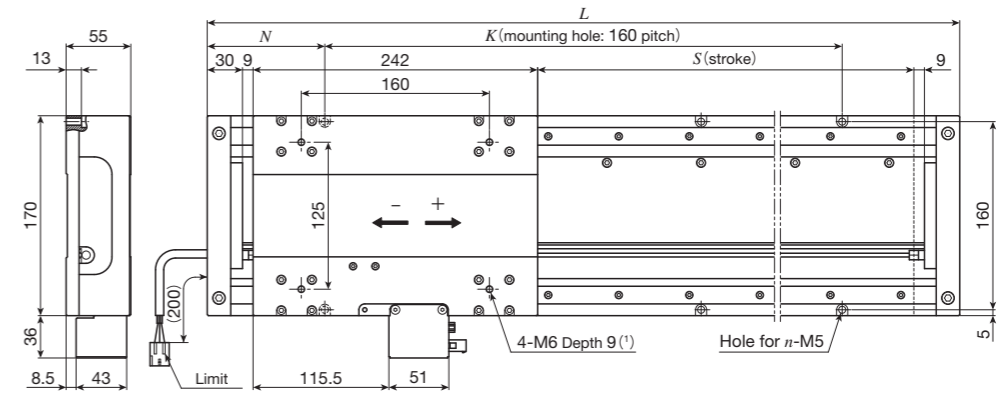

Identification number	Stroke length $S^{(2)}$	Overall length L	Mounting holes of bed			Total mass of table kg	Mass of moving table kg
			N	K	n		
LT170LDGS- 680 LT170LDVS- 680	680	1 000	100	800	12	22.6	2.5
LT170LDGS-1160 LT170LDVS-1160	1 160	1 480	100	1 280	18	32.7	
LT170LDGS-1640 LT170LDVS-1640	1 640	1 960	100	1 760	24	42.7	
LT170LDGS-2120 LT170LDVS-2120	2 120	2 440	100	2 240	30	52.8	
LT170LDGS-2600 LT170LDVS-2600	2 600	2 920	100	2 720	36	62.9	
LT170LDGS-2720 LT170LDVS-2720	2 720	3 040	80	2 880	38	65.4	

Notes (1) Too deep insertion depth of the mounting bolt may affect the running performance of the moving table, so never insert a bolt longer than the depth of the through hole.

(2) For other stroke lengths, please contact IKO.

LT170LDGS/T2 Twin table / High thrust specification LT170LDVS/T2 Twin table / High speed specification

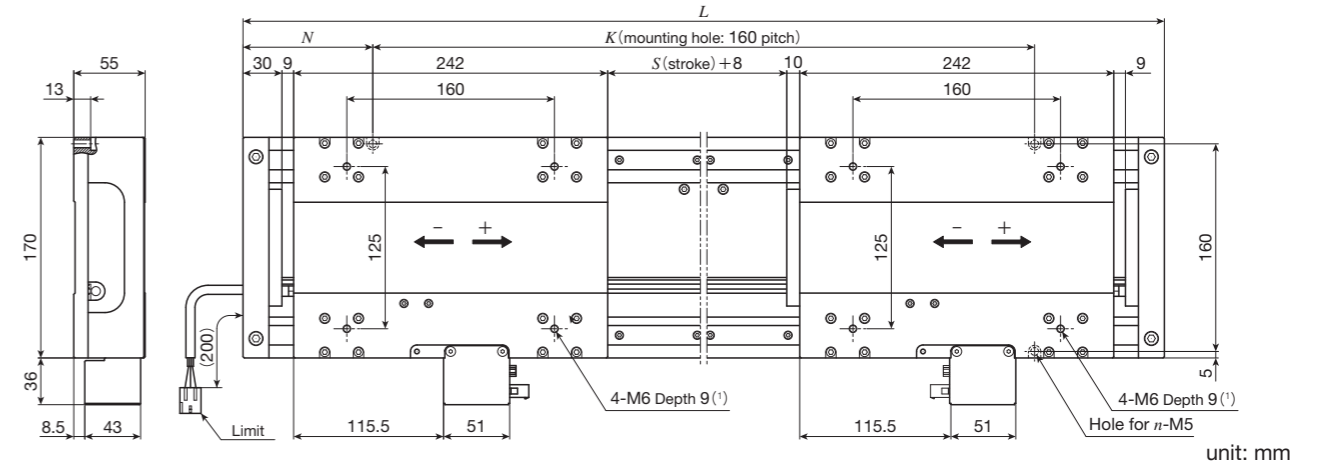

Identification number	Stroke length $S^{(2)}$	Overall length L	Mounting holes of bed			Total mass of table kg	Mass of moving table kg
			N	K	n		
LT170LDGS- 420/T2 LT170LDVS- 420/T2	420	1 000	100	800	12	25.1	2.5
LT170LDGS- 900/T2 LT170LDVS- 900/T2	900	1 480	100	1 280	18	35.2	
LT170LDGS-1380/T2 LT170LDVS-1380/T2	1 380	1 960	100	1 760	24	45.2	
LT170LDGS-1860/T2 LT170LDVS-1860/T2	1 860	2 440	100	2 240	30	55.3	
LT170LDGS-2340/T2 LT170LDVS-2340/T2	2 340	2 920	100	2 720	36	65.4	
LT170LDGS-2460/T2 LT170LDVS-2460/T2	2 460	3 040	80	2 880	38	67.9	

Notes (1) Too deep insertion depth of the mounting bolt may affect the running performance of the moving table, so never insert a bolt longer than the depth of the through hole.

(2) For other stroke lengths, please contact IKO.

IKO Linear Motor Table LT

- LT170LDGF/D Single table with cover / High thrust specification 1
- LT170LDTF/D Single table with cover / High thrust specification 2
- LT170LDVF/D Single table with cover / High speed specification

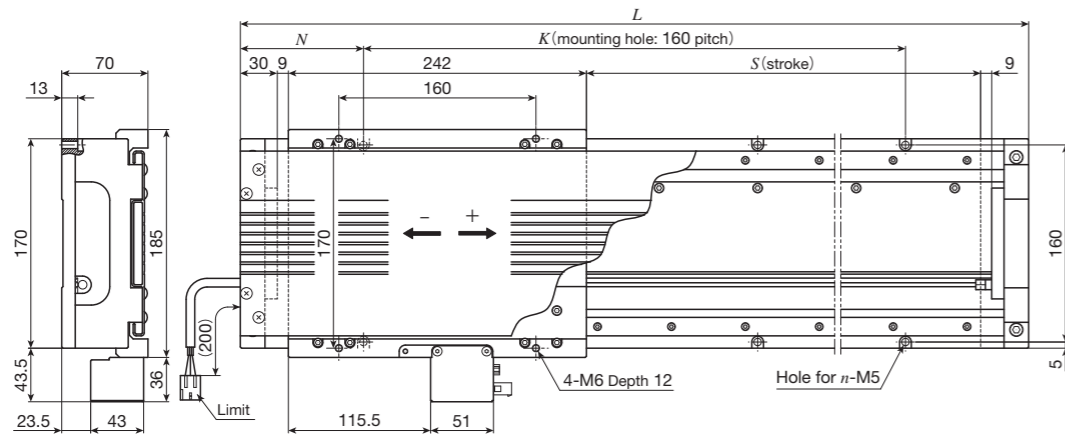

unit: mm

Identification number	Stroke length $S^{(1)}$	Overall length L	Mounting holes of bed			Total mass of table kg	Mass of moving table kg
			N	K	n		
LT170LDGF- 680/D LT170LDVF- 680/D	680	1 000	100	800	12	24.0	2.8
LT170LDGF-1160/D LT170LDVF-1160/D	1 160	1 480	100	1 280	18	34.6	
LT170LDGF-1640/D LT170LDVF-1640/D	1 640	1 960	100	1 760	24	45.2	
LT170LDTF- 680/D	680	1 000	100	800	12	24.7	
LT170LDTF-1160/D	1 160	1 480	100	1 280	18	35.6	
LT170LDTF-1640/D	1 640	1 960	100	1 760	24	46.5	

Note (1) For other stroke lengths, please contact IKO.

- LT170LDGF/DT2 Twin table with cover / High thrust specification 1
- LT170LDTF/DT2 Twin table with cover / High thrust specification 2
- LT170LDVF/DT2 Twin table with cover / High speed specification

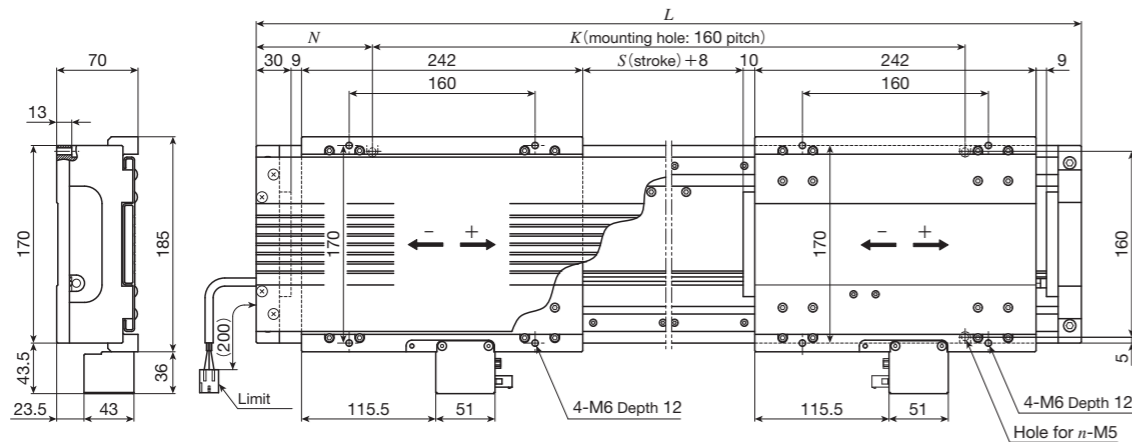

unit: mm

Identification number	Stroke length $S^{(1)}$	Overall length L	Mounting holes of bed			Total mass of table kg	Mass of moving table kg
			N	K	n		
LT170LDGF- 420/DT2 LT170LDVF- 420/DT2	420	1 000	100	800	12	26.9	2.8
LT170LDGF- 900/DT2 LT170LDVF- 900/DT2	900	1 480	100	1 280	18	37.5	
LT170LDGF-1380/DT2 LT170LDVF-1380/DT2	1 380	1 960	100	1 760	24	48.0	
LT170LDTF- 420/DT2	420	1 000	100	800	12	27.6	
LT170LDTF- 900/DT2	900	1 480	100	1 280	18	38.5	
LT170LDTF-1380/DT2	1 380	1 960	100	1 760	24	49.3	

Note (1) For other stroke lengths, please contact IKO.

LT170HS Single table

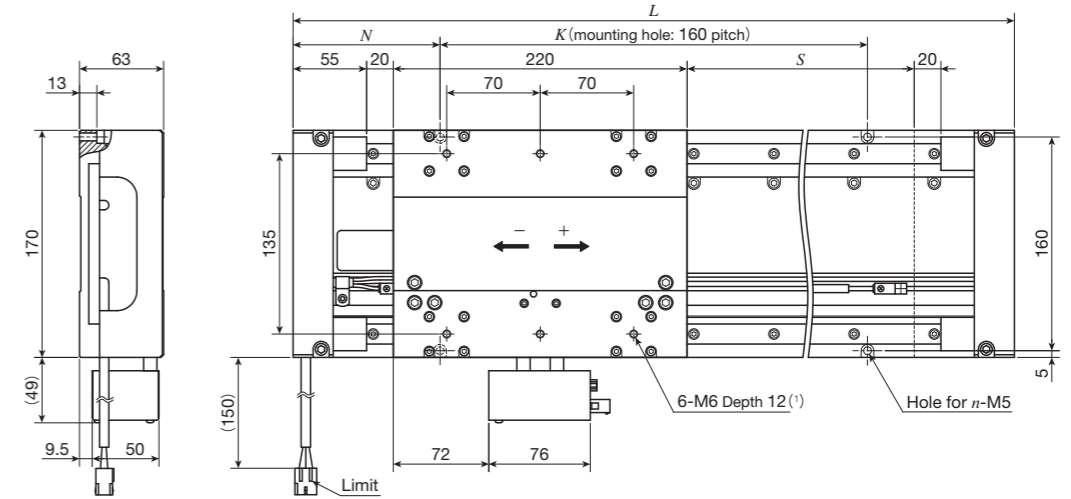

unit: mm

Identification number	Stroke length $S^{(2)}$	Overall length L	Mounting holes of bed			Total mass of table kg	Mass of moving table kg
			N	K	n		
LT170HS- 650	650	1 020	110	800	12	25.1	4.0
LT170HS-1130	1 130	1 500	110	1 280	18	34.9	
LT170HS-1610	1 610	1 980	110	1 760	24	44.6	
LT170HS-2090	2 090	2 460	110	2 240	30	54.4	
LT170HS-2570	2 570	2 940	110	2 720	36	64.1	
LT170HS-2670	2 670	3 040	80	2 880	38	66.4	

Notes (1) Too deep insertion depth of the mounting bolt may affect the running performance of the moving table, so never insert a bolt longer than the depth of the through hole.

(2) For other stroke lengths, please contact IKO.

LT170HS/T2 Twin table

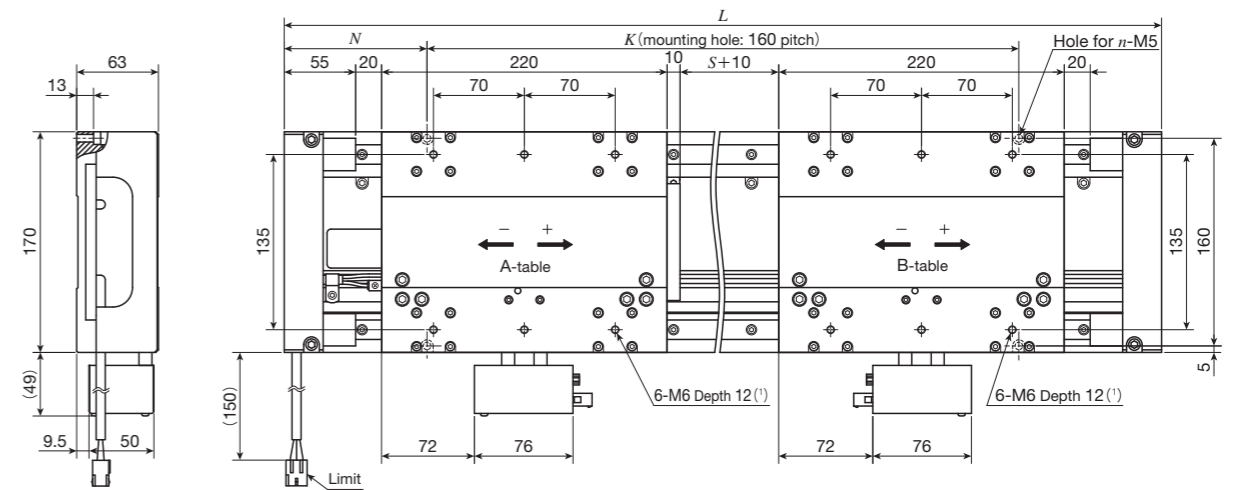

unit: mm

Identification number	Stroke length $S^{(2)}$	Overall length L	Mounting holes of bed			Total mass of table kg	Mass of moving table kg
			N	K	n		
LT170HS- 410/T2	410	1 020	110	800	12	29.1	4.0
LT170HS- 890/T2	890	1 500	110	1280	18	38.9	
LT170HS-1370/T2	1 370	1 980	110	1760	24	48.6	
LT170HS-1850/T2	1 850	2 460	110	2240	30	58.4	
LT170HS-2330/T2	2 330	2 940	110	2720	36	68.1	
LT170HS-2430/T2	2 430	3 040	80	2880	38	70.4	

Notes (1) Too deep insertion depth of the mounting bolt may affect the running performance of the moving table, so never insert a bolt longer than the depth of the through hole.

(2) For other stroke lengths, please contact IKO.

IKO Linear Motor Table LT

LT170HF/D Single table with cover

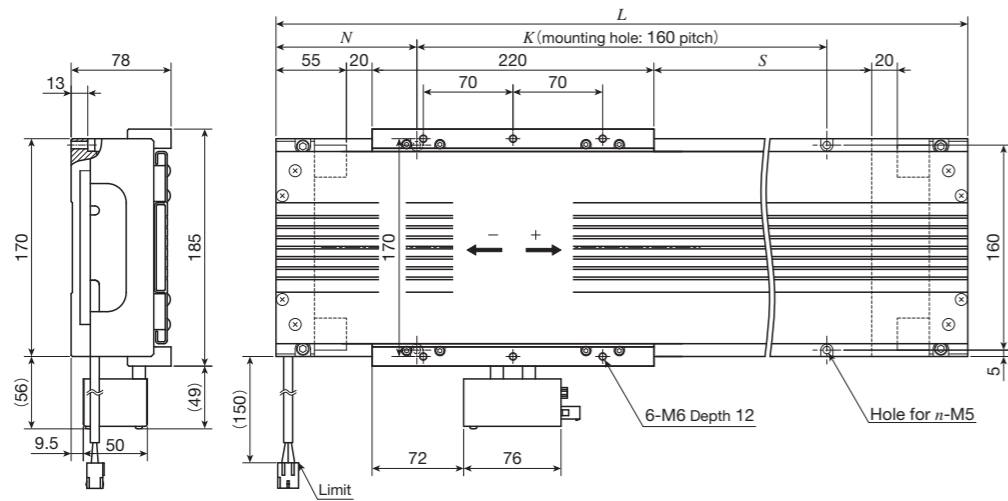

unit: mm

Identification number	Stroke length $S^{(1)}$	Overall length L	Mounting holes of bed			Total mass of table kg	Mass of moving table kg
			N	K	n		
LT170HF- 650/D	650	1 020	110	800	12	25.5	4.4
LT170HF-1130/D	1 130	1 500	110	1 280	18	35.2	
LT170HF-1610/D	1 610	1 980	110	1 760	24	45.0	

Note (1) For other stroke lengths, please contact IKO.

LT170HF/DT2 Twin table with cover

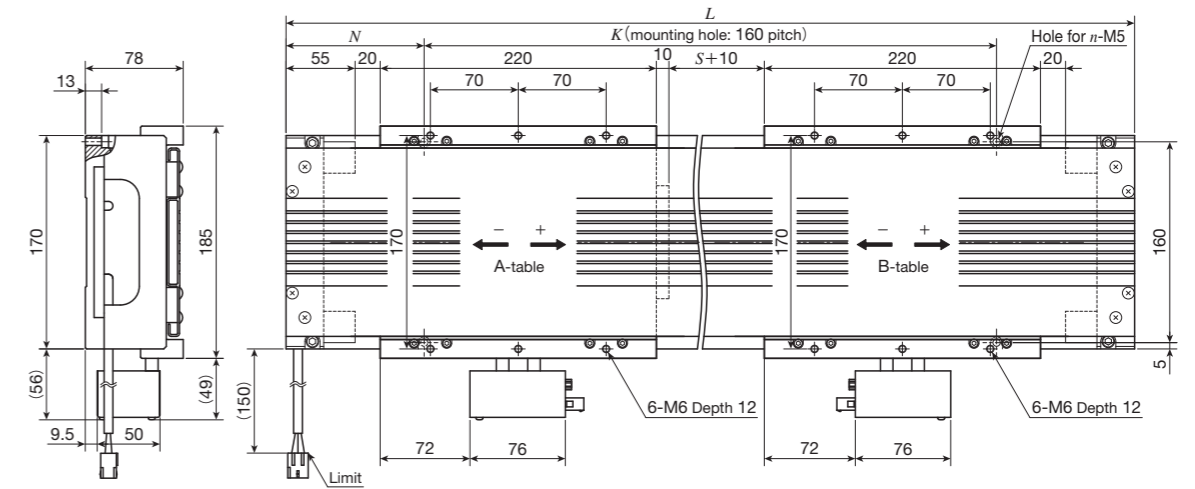

unit: mm

Identification number	Stroke length $S^{(1)}$	Overall length L	Mounting holes of bed			Total mass of table kg	Mass of moving table kg
			N	K	n		
LT170HF- 410/DT2	410	1 020	110	800	12	29.9	4.4
LT170HF- 890/DT2	890	1 500	110	1 280	18	39.6	
LT170HF-1370/DT2	1 370	1 980	110	1 760	24	49.4	

Note (1) For other stroke lengths, please contact IKO.